

KENWOOD

Document Copyrights

Copyright 2006 by Kenwood Corporation. All rights reserved.

No part of this manual may be reproduced, translated, distributed, or transmitted in any form or by any means, electronic, mechanical, photocopying, recording, or otherwise, for any purpose without the prior written permission of Kenwood.

Disclaimer

While every precaution has been taken in the preparation of this manual, Kenwood assumes no responsibility for errors or omissions. Neither is any liability assumed for damages resulting from the use of the information contained herein. Kenwood reserves the right to make changes to any products herein at any time for improvement purposes.



Photo is TK-390 K4 type.
Does not come with antenna.
Antenna is available as an option.

CONTENTS

GENERAL	2
SYSTEM SET-UP	2
OPERATING FEATURES	3
REALIGNMENT	11
CIRCUIT DESCRIPTION	17
SEMICONDUCTOR DATA	25
DESCRIPTION OF COMPONENTS	26
PARTS LIST	28
EXPLODED VIEW	36
PACKING	37
DISASSEMBLY FOR REPAIR	38
ADJUSTMENT	39
PC BOARD VIEWS	
FINAL UNIT (X45-3590-10)	50
CONTROL UNIT (X53-3930-XX)	51
TX-RX UNIT (X57-5400-XX)	55
SCHEMATIC DIAGRAM	61
BLOCK DIAGRAM	67
LEVEL DIAGRAM	69
TERMINAL FUNCTION	70
KNB-17A (Ni-Cd BATTERY)	71
KMC-25/26 (SPEAKER MICROPHONE)	72
KSC-19 (CHARGER)	73
KSC-20 (RAPID CHARGER)	73
KPG-36 (PROGRAMMING INTERFACE CABLE)	73
KRA-15 (ANTENNA)	73
SPECIFICATIONS	BACK COVER

CAUTION

When using an external power connector,
please use with maximum final module protec-
tion of 10V

GENERAL / SYSTEM SET-UP

INTRODUCTION

SCOPE OF THIS MANUAL

This manual is intended for use by experienced technicians familiar with similar types of commercial grade communications equipment. It contains all required service information for the equipment and is current as of the publication data. Changes which may occur after publication are covered by either Service Bulletins or Manual Revisions. These are issued as required.

ORDERING REPLACEMENT PARTS

When ordering replacement parts or equipment information, the full part identification number should be included. This applies to all parts : components, kits, or chassis. If the part number is not known, include the chassis or kit number of which it is a part, and a sufficient description of the required component for proper identification.

PERSONNEL SAFETY

The following precautions are recommended for personnel safety :

- DO NOT transmit until all RF connectors are verified secure and any open connectors are properly terminated.
- SHUT OFF and DO NOT operate this equipment near electrical blasting caps or in an explosive atmosphere.
- This equipment should be serviced by a qualified technician only.

SERVICE

This radio is designed for easy servicing. Refer to the schematic diagrams, printed circuit board views, and alignment procedures contained within.

NOTE

WE CANNOT guarantee oscillator stability when using channel element manufactured by other than KENWOOD or its authorized agents.

Unit Model & destination		X57-540X-XX			X53-393X-XX				X45-359X-XX	Frequency range	Remarks	DTMF keypad
		0-10	0-11	0-12	0-13	0-14	0-15	0-16	0-10			
TK-390	K	✓			✓					450~490MHz	1st IF : 44.85MHz LOC : 44.395MHz	-
	K4	✓				✓				450~490MHz		✓
	K2		✓		✓					470~512MHz		-
	K3			✓			✓		✓	403~430MHz		-
	K6			✓				✓	✓	403~430MHz		✓

SYSTEM SET-UP

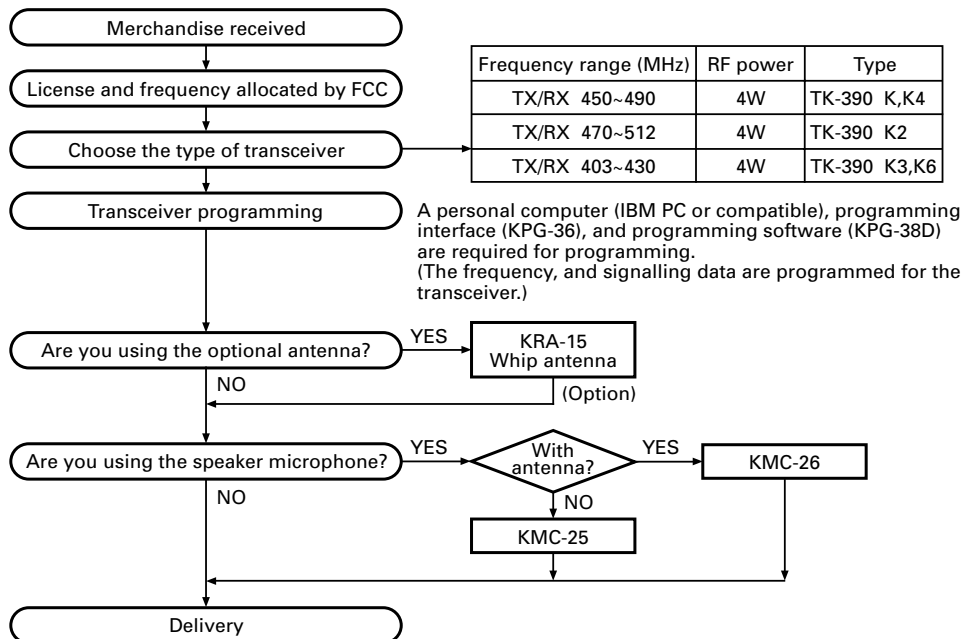

OPERATING FEATURES

1. Getting Acquainted

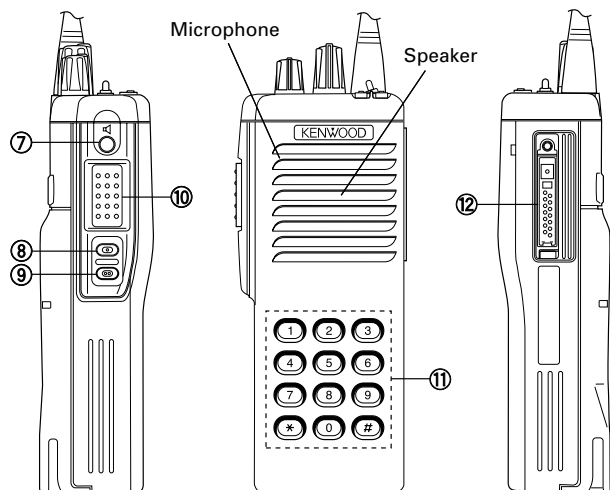
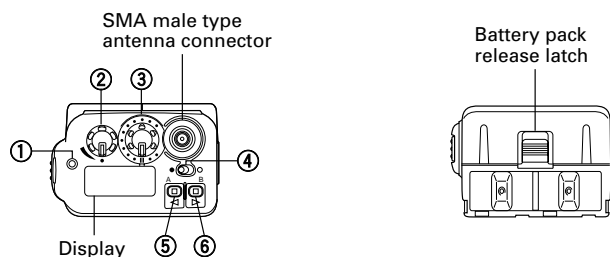

1-1. Key Descriptions

① TX/Busy/Battery low indicator

Lights red while transmitting. Lights green while receiving. Flashes red when the battery power is low while transmitting; replace or recharge the battery.

Note : This indicator can be disabled by your dealer.

② Power switch/Volume control

Turn clockwise to switch ON the transceiver. Turn counterclockwise, until a click sounds, to switch OFF the transceiver. Rotate to adjust the volume level.

③ Selector

Rotate this control to activate its programmable function (Page 8).

④ Toggle switch

Switch the toggle position to activate its programmable function (Page 8).

⑤ Top 1

⑥ Top 2

⑦ Orange

⑧ Side 1

⑨ Side 2

Press these PF (programmable function) keys to activate their programmable functions (Page 8)

⑩ PTT (Push-To-Talk) switch

Press this switch, then speak into the microphone to call a station.

⑪ DTMF keypad (keypad models only)

Press the keys on the telephone keypad to send DTMF tones.

⑫ Universal connector

Connect the external speaker/microphone (optional) here. Otherwise, keep the supplied cover in place.

1-2. Display

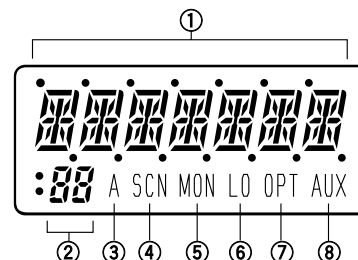

① Alphanumeric display

Displays the operating group or channel number, or the group or channel name. When making a DTMF or 2 Tone call, the display will alternate between CALL and the channel. Also displays various menu functions.

② 7 Segment display

Displays the operating group or channel number. Also displays tA (Talk Around), P1 (Priority1), P2 (Priority2), PP (Priority1 and Priority2), or HC (Home Channel); depending on the function being used.

③ A (Add) indicator

Appears when a channel is added to the scanning sequence.

④ SCN (Scan) indicator

Appears when Scan mode is active.

⑤ MON (Monitor) indicator

Appears when the monitor function is active.

⑥ LO (Low) indicator

Appears when low power is selected.

⑦ OPT indicator

Appears when Operator Selectable Tone is enabled.

⑧ AUX (Auxiliary) indicator

Appears when Aux is ON. Appears and blinks when the optional scrambler board is enabled.

Note : The alphanumeric and 7 segment displays can be inverted if a PF key or the toggle switch is programmed with Invert Display (Page 8).

OPERATING FEATURES

2. Scan Operating

2-1. Scan Types

• Single Group Scan

You can scan all valid (ADD) channels in the displayed group that can be selected with the group selector.

• Multiple Group Scan

You can scan all valid (ADD) channels in the all valid (ADD) group.

2-2. Scan Start Condition

One or more non-priority channels must be added to all channels that can be scanned. The transceiver must be in normal receive mode (PTT off).

When you activate the key or the toggle switch (to right position) programmed to the scan function, the scan starts. The scan icon "SCN" lights and "SCAN" or revert channel (programmable) is indicated on 7-digit alphanumeric display.

2-3. Scan Stop Condition

The scan stops temporarily if the following conditions are satisfied.

- 1) A carrier is detected, then signalling matches on channels for which receive the signalling is set by the programming software.
- 2) A carrier is detected on the channel for which receiving signalling is not set by the programming software or when the monitor (signalling cancel) function is activated.

2-4. Scan Channel Types

- 1) Priority channel 1 is the most important channel for the scan, and always detects a signal during scan and when the scan stops temporarily.
- 2) Priority channel 2 is the next important channel for the scan, and always detects a signal during scan and when the scan stops temporarily at a channel other than priority channel 1.
- 3) Non-priority channels detects a signal during scan. For the channels that can be selected with the group or channel selector when the scan does not occur, adds an indicator "A" lights.

2-5. Priority Channel Setting

Priority channels 1 or 2 can be set as follows with the programming software (KPG-38D).

- 1) Specify priority channels 1 or 2 as fixed priority channels.
- 2) Make selected channels, priority channels.
- 3) Operator delectable
Specify the initial channel before the operator changes it.

2-6. Scan Type According to the Priority Channel

- 1) When no priority channels are set : Only the non-priority channels are scanned.
If a non-priority channel stops temporarily, it stops until there is no signal on the channel.

- 2) When one priority channel is set : Either priority channel 1 or 2 is scanned.
If a non-priority channel stops temporarily, a priority channel signal is detected at certain intervals.
If a priority channel stops temporarily, it stops until there is no signal on the priority channel.
- 3) When two priority channels are set : The non-priority channel, priority channels 1 and 2 are scanned.
If a non-priority channel stops temporarily, priority channel 1 and 2 signals are detected at certain intervals.
If priority channel 2 stops temporarily, the priority channel 1 signal is detected at certain intervals.
If priority channel 1 stops temporarily, it stops until there is no signal on priority channel 1.

2-7. Revert Channel

The revert channel is used to transmit during scanning and set by the programming software (KPG-38D).

- 1) Priority 1
The transceiver reverts to the priority channel 1.
- 2) Priority 1 with talkback
The transceiver reverts to the priority channel 1.
If you press PTT during a resume timer (dropout delay time, TX dwell time) or calling, you can transmit on current channel to answer to the call however revert channel is set to priority channel 1.
After resume time, scan re-starts and transmission channel is return to priority channel 1.
- 3) Priority 2
The transceiver reverts to the priority channel 2.
- 4) Priority 2 with talkback
The transceiver reverts to the priority channel 2.
If you press PTT during resume timer (dropout delay time, TX dwell time) or calling, you can transmit on current channel to answer to the call however revert channel is set to priority channel 2.
After resume time, scan re-starts and transmission channel is return to priority channel 2.
- 5) Selected channel
The transceiver reverts to the channel before scanning or the channel that you changed during scan.
- 6) Last called channel
The transceiver reverts to the last called channel during the scan.
- 7) Last used channel
The transceiver reverts to the last used (transmitted) channel during scan. "Last used" revert channel includes talkback function.
- 8) Selected with talkback
The transceiver reverts to the channel before scanning or the channel that you changed during scan.

2-8. Scan End

When you reactivate the key or the toggle switch (to left position) programmed to the scan function during scan mode, the scan ends.

The scan icon "SCN" and "SCAN" or revert channel (programmable) display goes off.

OPERATING FEATURES

2-9. Temporarily Delete/Add

It is possible to delete or add channel temporarily during scan. When scan stops on unnecessary channel for example by interference of the other party, activate the delete/add function (for example press the key), then that channel is deleted temporarily and scan re-start immediately.

When you would like to add the deleted channel temporarily to scan sequence, select the desired (deleted) channel during scan, activate the delete/add function (for example press the key) before scan re-start.

That channel is added temporarily to scan sequence. The temporary deleted or added channels are returns to pre-set delete/add, when the transceiver exits from scan mode.

3. Optional Features

You can use these features using the programming software (KPG-38D).

3-1. Alphanumeric Display (Group/Channel Name)

The programming software (KPG-38D) enables you to set the alphanumeric display for group/channel name. The total text size of group and channel name are 7-digits.

For example, If you set 2-digits for group name, then you can use 5-digits for channel name. The characters can be used as shown in Figure 1.

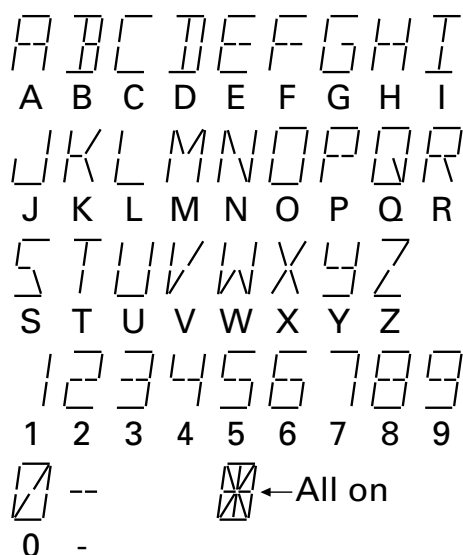

Fig. 1

3-2. Beep Tones

The beep tones (power on tone, control tone, warning tone, alert tone) are individually programmable to the fixed level 0 to 31 or follow the mechanical volume position.

3-3. Minimum Volume

The minimum volume is programmable (0 to 31). The transceiver remains the minimum volume level however the mechanical volume position is set to zero.

3-4. Squelch Threshold Level

Squelch threshold level value.
0 (Most loose)~15 (Most tight)

3-5. BCL (Busy Channel Lockout) Override

You can transmit in spite of Busy Channel Lockout situation. For example : To make an emergency voice call.

To transmit under busy channel lockout situation, press PTT once more within approx. 500ms after the PTT release.

3-6. Selective Call Alert LED

You can select whether or not the LED on the transceiver flashes in an orange color when Selective call was occurred.

3-7. Battery Warning

This transceiver has battery warning feature. If the low voltage is detected during transmission, the transceiver warns it by flashing red "LED".

Then more low voltage is detected during transmission, the transceiver stops transmission and warns it by flashing red "LED" and beep.

Please notice "standard" for the battery exchange, charging time by flashing red LED and beep.

3-8. Busy LED

You can program the enable or disable the busy "LED" function when a carrier is detected. "Disable" saves battery life.

3-9. TX LED

You can program the enable or disable the transmission "LED" function.

3-10. 2-Digit 7-Segment Display

You can use 2-digit 7-segment the display to display the channel number or group number. It is useful when the main (7-digit 13-segment) display indicates group or channel name.

3-11. Invert Display

Main (7-digit 13-segment) display and sub (2-digit 7-segment) display can be programmed to invert display.

It is easy to read the display when the operator suspended the transceiver on a waste belt. The operator also can change the display between normal and invert using key. Refer the invert display function of key function.

3-12. Clear to Transpond

The transceiver waits the transpond of 2-Tone/DTMF if channel is busy until channel open. This feature prevents the interference to other party.

3-13. External Speaker

It can be selected if the receive sound is made by SP-Mic SP or the main body SP at a SP-Mic mount.

3-14. Noise Cancelling MIC

Enable or disable the noise cancelling function of the internal microphone. It is not valid for the external SP/MIC.

OPERATING FEATURES

3-15. Mode (Enable/Disable)

The transceiver has many special modes mainly for maintenance.

- Self Programming mode
- Panel Test mode
- Clone mode
- Firmware Programming mode
- Version info.

It is possible to set enable/disable for each mode. We recommend to set these mode to Disable after set up to save contents.

3-16. ID

The transceiver is capable to have ID. The format is DTMF, MSK or ANI board (if installed). The timing that the transceiver sends ID is programmable.

Connect ID : Connect ID is send on beginning of transmission.

Disconnect ID : Disconnect ID is send on end of transmission.

Both : Connect ID is send on beginning of transmission and disconnect ID is send on end of transmission.

Off : Sending ID function is disabled.

There is also "PTT ID" setting for each channel. Refer "PTT ID" of channel feature.

When you use an ID code for ANI board, the ID code and transmitting timing are configured to the optional ANI board.

3-17. OST (Operator Selectable Tone)

The transceiver is capable to have "OST" function and 16 tone pair (QT/DQT) with max 7-digit name for each tone pair.

• "OST" Back Up

The transceiver is programmable the selected "OST" code is memorized or not. If you set to Disable (no memorized), the "OST" function always starts at "off".

• Direct "OST"

It is possible to call "OST" number directory using keypad. In this case, keypad is used for "OST", then "DTMF Auto PTT", "DTMF Auto Dial" functions by keypad are not usable.

3-18. Emergency

• Active Time

Automatic transmission period in the emergency mode.

• Interval Time

Interval time between the automatic transmissions.

• Duration of Locator Tone 1

Duration of an alert tone before the automatic transmission is performed.

• Duration of Locator Tone 2

Duration of an alert tone after the automatic transmission is performed.

• Man Down Delay Time

Delay time of entering the emergency mode when the internal Man Down port becomes active.

• Man Down Pre-alert

Wait time of the alert tone when the internal Man Down port becomes active to enter the emergency mode. (After an alarm sounds, the transceiver waits for the programmed wait time then enter the emergency mode.)

• Emergency Channel Display

Setting for the display in the emergency mode.

The transceiver can be programmed to display "EMERGENCY" channel name when it is in emergency mode.

If you set to "off" by KPG-38D the transceiver shows selected group/channel/status before entering to the emergency mode however the transceiver is in an emergency mode.

• Emergency Mode Type

Speaker mute on or off in the emergency mode.

• Emergency Type

Select an Emergency code format from DTMF, MSK, ANI board or OFF (Disabled).

• Emergency DTMF ID

The Fleet number when you select DTMF in the emergency type.

• Emergency Call Fleet

The emergency fleet number when you select MSK in the emergency type.

• Emergency Call ID

The emergency DTMF ID code when you select MSK in the above emergency type.

3-19. Radio Password (Keypad Model Only)

The radio password prevent unauthorized users operation. Every time the power on, transceiver is locked and unusable until entering correct password.

Enter pre-programmed password by FPU and [#] key causes the transceiver unlocked.

3-20. Data Password

The data password prevents unauthorized reading of the programmed transceiver data by FPU. Enter pre-programmed password in FPU reading process. This password also protects the clone.

Enter pre-programmed password by FPU and [#] key to clone.

OPERATING FEATURES

4. Group Features

You can use these features using the programming software (KPG-38D).

4-1. "TOT" (Time-Out Timer)

The transceiver has the "TOT". This parameter selects the period of time users can continuously transmit.

When the selected period passes, the transceiver generates a warning tone and stops the transmission.

4-2. "TOT" Pre-Alert

The transceiver has "TOT" pre-alert timer. This parameter selects the time at which the transceiver generates "TOT" pre-alert tone before "TOT" is expired.

"TOT" will be expired when the selected time passes from a TOT pre-alert tone.

4-3. "TOT" Re-Key Time

The transceiver has "TOT" re-key timer. This timer is the time you can not transmit after "TOT" exceeded. After "TOT" re-key time expired you can transmit again.

4-4. "TOT" Reset Time

The transceiver has "TOT" reset timer. This timer is the minimum wait time allowed during a transmission that will reset the "TOT" count.

"TOT" reset time causes the "TOT" to continue even after PTT is released unless the "TOT" reset timer has expired.

4-5. Group Delete/Add

The transceiver can set the delete/add in each group. If "Delete" is selected, the transceiver does not scan the deleted group in multi group scan.

4-6. Battery Save

This is the automatic battery saver during a standby mode operation. The receiver circuit is repeated on and off to conserve the battery life.

4-7. Signalling

Signalling "AND/OR" sets the audio unmute condition for any channel programmed with the option signalling (2-Tone/DTMF).

AND : "AND" requires both the valid option signalling and the programmed QT/DQT to be received for audio to unmute (and initiate an option signalling decode alert).

OR : "OR" requires either the valid option signalling or the programmed QT/DQT to be received for audio to unmute (an option signalling decode alert is only initiated if the proper option signalling is decoded).

5. Channel Features

You can use these features using the programming software (KPG-38D).

5-1. Option Signalling

The transceiver is programmable to the option signalling (2-Tone decode program 1, 2-Tone decode program 2, 2-Tone decode program 3, DTMF decode) to each channel. It is useful to receive an individual call.

Receive format is selectable "AND" or "OR" with QT/DQT for each group. The radio response of option signalling is programmable "(Call) Alert tone" or "Transpond" for each option signalling (2-Tone decode program 1, 2-Tone decode program 2, 2-Tone decode program 3, DTMF).

5-2. PTT ID

PTT ID provides a DTMF ANI, MSK ANI or ANI board ID (if installed) to be sent with every time PTT (connect ID at beginning of transmission, disconnect ID at end of transmission, or both).

You can program PTT ID "on" or "off" for each channel. The contents of ID are programmed for each transceiver.

5-3. Busy Channel Lockout

Transmission is inhibited when the channel is busy. It is able to set this feature "Yes" or "No" for each channel.

5-4. Beat Shift

This is the feature that the microprocessor shifts its system clock frequency slightly to prevent the receive interference. This transceiver can program this feature "Yes" or "No" for each channel.

5-5. TX Power

You can set the transmission power "High" or "Low" for each channel. The each power setting is tuned at factory.

However, you can re-tune the power, using PC Tuning Mode of KPG-38D.

5-6. Wide/Narrow

You can set the occupied band width mode "Wide" or "Narrow" for each channel. It is useful for the operator to use the transceiver on various sites.

5-7. Scan Delete/Add

Scanning "delete/add" is programmable for each channel. Set the currently selected channel required to include in the scan sequence to "add".

The operator can change the "delete/add" information using the key programmed to "delete/add" function.

5-8. Compander

This function reduces the noise on the communications channel used by the transceiver and improves reception.

If Wide/Narrow function is set to wide, this function doesn't perform.

OPERATING FEATURES

6. Key Functions

You can use these features, using the programming software (KPG-38D). Selector function is selectable channel select or group select.

The functions for Toggle switch are listed page 8 (Fig. 2). Right position is active for programmed function on toggle switch except "group select".

The functions for the top key are listed page 8 (Fig.2). Hold action and shift action are programmable.

The functions for side key are listed page 8 (Fig.2). Hold action and shift action are programmable.

The functions for microphone key are listed page 8 (Fig.2). Hold action is programmable.

6-1. No Function

Sounds error operation beep, and no action will occur. Use this function when the transceiver is required to be more simple operated.

6-2. AUX.

This function can be programmed when the voice scrambler board is not installed.

If this key is pressed, "AUX" icon lights on the LCD and AUX port which is inside of the transceiver turns to the high level. If pressed again, the "AUX" icon goes off and the AUX ports turns to the lower level.

6-3. Channel Down

If this key is pressed once, the channel number decreases by one step. If this key holds down for 500ms (approximate), the channel number decreases continuously.

This key works as the squelch level adjuster in a squelch level adjust mode. This key works as the OST (operator selectable tone) number selector in the OST mode. This key works as the SCR (voice scrambler) code selector in the voice scrambler code select mode.

6-4. Channel Up

If this key is pressed once, the channel number increases by one step. If this key holds down for 500ms (approximate), channel number increases continuously.

This key works as the squelch level adjuster in squelch level adjust mode. This key works as the OST (operator selectable tone) number selector in the OST mode. This key works as the SCR (voice scrambler) code selector in the voice scrambler code select mode.

6-5. Channel Name

This key switches the LCD display between the group/channel number and the group/channel name.

6-6. Delete/Add

This key switches the currently displayed channel between "Delete" and "Add".

The "Add" channel contained in the scan sequence, and "Delete" channel is not contained. In the scan mode, this key switches the channel delete or add temporarily.

Function Name	Selector ③	Toggle Switch ④	PF Keys ⑤ ⑥ ⑦ ⑧ ⑨	Speaker/ Microphone PF Keys
Aux ¹		✓	✓	✓
Channel Down			✓	✓
Channel Name			✓	✓
Channel Select	✓			
Channel Up			✓	✓
Delete/Add			✓	✓
Emergency Call ²			✓	✓
Group Down			✓	✓
Group Scan		✓		
Group Select	✓	✓		
Group Up			✓	✓
Home Channel			✓	✓
Invert Display		✓	✓	✓
Key Lock		✓	✓	✓
Lamp			✓	✓
Low Power		✓	✓	✓
Monitor		✓	✓	✓
Monitor Momentary			✓	✓
No Function		✓	✓	✓
Operator Selectable Tone			✓	✓
Operator Selectable Priority 1			✓	
Operator Selectable Priority 2			✓	
Scan		✓	✓	✓
Scrambler ³		✓	✓	✓
Shift		✓	✓	
SP Attenuation				✓
Squelch Level			✓	✓
Squelch OFF		✓	✓	✓
Squelch Momentary			✓	✓
Talk Around		✓	✓	✓

1 This function can be selected when the scrambler board has not been installed.

2 This function can be selected when the ANI board has been installed.

3 This function can be selected when the scrambler board has been installed.

Note : If "Shift" is programmed onto one of the PF keys or the toggle switch, the remaining PF keys can be programmed with two different functions. If "Shift" is programmed onto a PF key and the toggle switch, an error will occur and the function will not operate.

Fig. 2 Programmable functions

OPERATING FEATURES

6-7. Group Down

If this key is pressed once, the group number decreases by one step. If this key holds down for 500ms (approximate), the group number decreases continuously.

This key works as the squelch level adjuster in squelch level adjust mode. This key works as the OST (operator selectable tone) number selector in the OST mode. This key works as the SCR (voice scrambler) code selector in the voice scrambler code select mode.

6-8. Group Up

If this key is pressed once, the group number increases by one step. If this key holds down for 500ms (approximate), the group number increases continuously.

This key works as the squelch level adjuster in the squelch level adjust mode. This key works as the OST (operator selectable tone) number selector in the OST mode. This key works as the SCR (voice scrambler) code selector in the voice scrambler code select mode.

6-9. Home Channel

Press this key once, the channel switches to the pre-programmed home channel. Press this key again, the channel goes back to the previous channel.

6-10. Invert Display

Press this key once, the displayed the group/channel number or group/channel name are inverted. Press this key again, the display returns to the normal.

For the operator who does not change the display and needs "Invert" only, refer "Invert Display" setting of optional feature.

6-11. Key Lock

Pressing this key causes the transceiver to accept an entry of only the [Shift], [KeyLock], [PTT], [Emergency], [LAMP], [Monitor], [Monitor Momentary], [Squelch Off], [Squelch Momentary], [SP MIC Attenuation] keys, [Selector switch], [Volume], [Toggle], [Lamp], [Moni], [Moni momentary], [SQ off] and [SQ momentary].

"Lock" is used to prevent users from unexceptionable key press which might cause a transceiver malfunction. The display does not change while the key is being locked.

Switching the transceiver off and on or pressing Key Lock again cancels the key lock. Key locked transceiver can still receive. Pressing this key while scanning, keys are locked but a scanning continues.

6-12. Lamp

Press this key, the transceiver illuminates the display and keypad back lit approximate 5 seconds. Press this key again, the transceiver stops the illuminating.

Pressing any key except the LAMP key while the illuminated restarts the 5 second timer.

6-13. Low Power

Press this key, the transmission power of all channel changes to Low. Press this key again, the transmission power returns to programmed value.

6-14. Monitor

Monitor the channel before a transmission.

Press this key once, "MON" appears and unmutes speaker if a carrier is present, regardless of the specified signalling (including option signalling). Press this key again, "MON" disappears and mutes speaker.

Press this key after the Option Signalling is matched, the Option Signaling is reset and monitor is activated. DBD (Dead Beat Disable) mode is not reset by this operation.

6-15. Monitor Momentary

While pressing this key, the monitor function (refer 6-14) is activated. Release this key, the monitor function is deactivated.

6-16. Operator Selectable Tone

This key switches the pre-set decode QT/DQT and encode QT/DQT to OST (Operator Selectable Tone) tone pair.

Press this key, the transceiver enters to OST select mode. In this mode, the display shows "OFF" and the operator can select one of the OST tone pair using the channel up/down key or the group up/down key. The display shows "TONE **" and tone pair No. ** is selected.

Press OST key again, the transceiver exits from the OST select mode, and returns to the group/channel mode with "OPT" icon. "OPT" icon means that the OST tone pair is selected. OST tone pair number or OFF can be memorized for each channel.

16 kinds of tone pair for OST can be programmed by KPG-38D. OST is useful to access the repeater with same radio frequency and different tone (QT/DQT).

6-17. Operator Selectable P1

If priority channel 1 is set as "Fixed" and "None" in the scan information. The operator can select the priority channel 1, using this key (operator selectable fixed P1).

Press this key on normal channel, the channel becomes to priority channel 1. Previous priority channel 1 returns to the normal channel. Press this key on the priority channel 1, the priority 1 will be lost (no priority 1).

6-18. Operator Selectable P2

If priority channel 2 is set as "Fixed" and "None" in the scan information. The operator can select the priority channel 2, using this key (operator selectable fixed P2).

Press this key on the normal channel, the channel becomes to the priority channel 2. Previous priority channel 2 returns to the normal channel. Press this key on priority channel 2, the priority 2 will be lost (no priority 2).

6-19. Scan

Press this key starts scanning. Pressing this key stops scanning.

6-20. Shift

This key activates "Shift + [Key]" function. It is useful when the numbers or more of the functions are necessary.

OPERATING FEATURES

6-21. Squelch Level

The preset squelch level is varied in user mode (0 to 15). Press the key programmed to "squelch level", the transceiver enters to "squelch level adjust mode".

The squelch level can be adjusted by group "up/down" function key or channel "up/down" function key. Press the key programmed to "squelch level" again, the adjusted level is memorized and returns to the normal user mode.

6-22. Squelch Momentary

While pressing this key, the transceiver unmutes speaker regardless of an existence of a carrier and "MON" appears and busy "LED" lights on.

Release this key, the transceiver mutes the speaker and "MON" disappears and busy "LED" lights off.

6-23. Squelch Off

Press this key, the transceiver unmutes speaker regardless of the existence of a carrier and "MON" appears and busy "LED" lights.

Press this key again, the transceiver mutes the speaker and "MON" disappears and busy "LED" lights off.

6-24. Talk Around

Press this key, the transceiver uses the receive frequency and the tone for transmission.

The operator can call the other party directory (without repeater). Press this key again, the talk around function goes off.

6-25. Emergency Call

Press this key, the transceiver enters to an emergency mode. In this mode, the channel is switched to the programmed emergency channel automatically and starts transmission with an emergency ID code which is programmed to ANI board.

The display depends on "Emergency Channel Display" setting.

6-26. SP Attenuation

Press this key once, the volume level of speaker-microphone is attenuated. Press this key again, the volume level of speaker-microphone returns to the previous level.

7.2-Tone

Built-in 2-Tone decoder (decoder program 1, decoder program 2, decoder program 3) is available for option signalling. It is possible to use individual call or group call.

8. DTMF

Built-in DTMF encoder is available for dialing (Manual dial, Auto-dial (9 memory), Re-dial (1 memory)) (Keypad model only). Built-in DTMF decoder is available for option signalling.

It is possible to use individual call, group call, DBD (Dead Beat Disable).

9. Data Programming (PC Mode)

9-1. Preparation and Connection

TK-390 transceiver is programmed by using a personal computer, programming interface cable KPG-36, and programming software KPG-38D.

The programming software can be used with an IBM-PC or compatible machine. Figure 3 shows the setup for programming.

9-2. Programming Interface Cable KPG-36 Description

The KPG-36 is required to interface TK-390 to the computer. It has a circuit in its D-sub 25pin connector case that converts RS-232C logic level to TTL level.

KPG-36 is used to connect between TK-390 universal connector and RS-232C serial port of computer.

9-3. Programming Software KPG-38D Description

KPG-38D is the programming software for TK-390 supplied on a 3.5" floppy disk. This software runs under MS-DOS version 3.1 or later on an IBM-PC/XT, AT, or PS2 or compatible machine.

The data can be input to or read from TK-390 and edited on the screen. The programmed or edited data can be printed out. It is also possible to tune the transceiver.

We recommend that install KPG-38D for example to harddisk first then use it.

KPG-38D instruction manual part No. : B62-0814-XX.

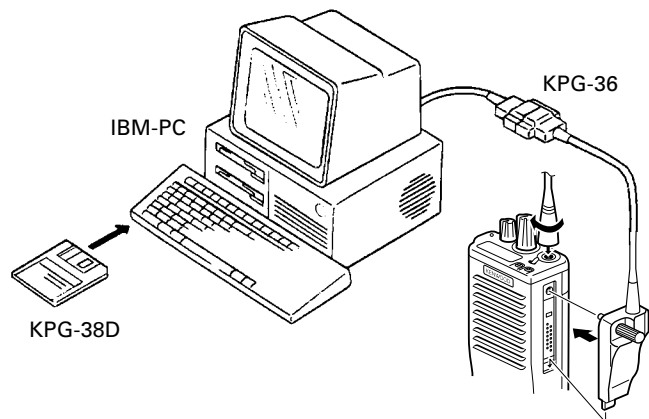
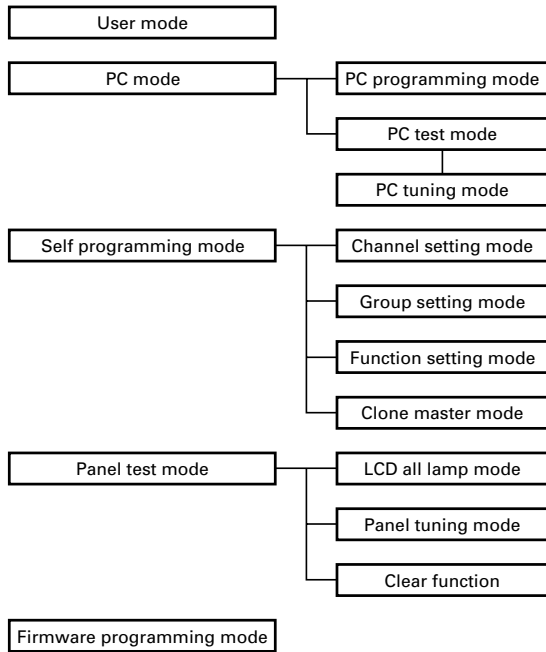

Fig. 3

REALIGNMENT

1. Mode



Mode	Function
User mode	Customer use this mode
PC mode	Communication between the radio and PC (IBM compatible). It requires the KPG-38D
PC programming mode	Frequency, signalling and features write to the radio and read from the radio.
PC test mode	Check the radio using the PC. This feature is included in the FPU.
Self programming mode	Frequency, signalling and features write to the radio.
Panel test mode (Refer to Adjustment)	Dealer use to check the fundamental characteristics.
Firmware programming mode	Re-write the firmware of the flash ROM.

2. How to Enter Each Mode

Mode	Operation
User mode	Power on
PC mode	Power on begins the USER MODE.
Self programming mode	Hold down the [Side 1] key and the [Side 2] key, turn the radio power on.
Panel test mode	Hold down the [Side 2] key and [PTT], turn the radio power on, and release [PTT] first.
Firmware programming mode	Held down the [Side 2] key and [PTT], turn the radio power on, and release [Side 2] key first.

3. Self Programming

Write mode for frequency data and signalling etc. Mainly used by the person maintaining the user equipment.

3-1. Enter to the self programming mode

Turn the power switch on, with the lead wire with plug PF (8 pin) shorted to the E (10 pin) lead (Figure 5), or delete R491 (SELF, Figure 6) in the TX-RX unit and turn the power switch on while pressing the [Side 1] and [Side 2] keys.

Note :

This mode (self programming mode) cannot be set when it has been disabled with the FPU.

• Additional Modification of the Plug

It's available to enter the self programming mode by modifying the pattern of lead wire as following.

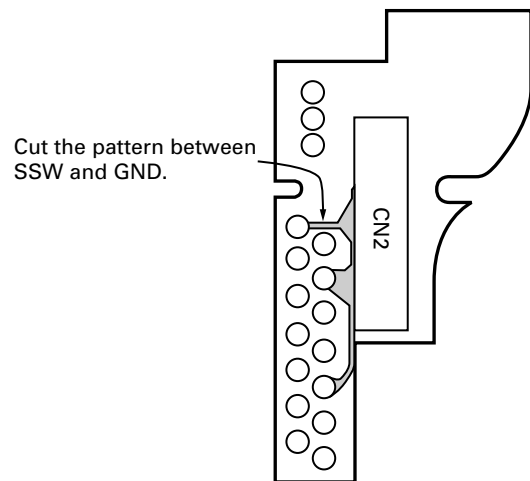

Fig. 4

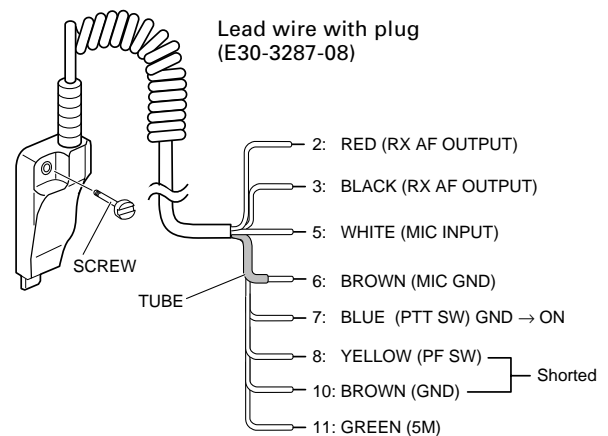

Fig. 5

REALIGNMENT

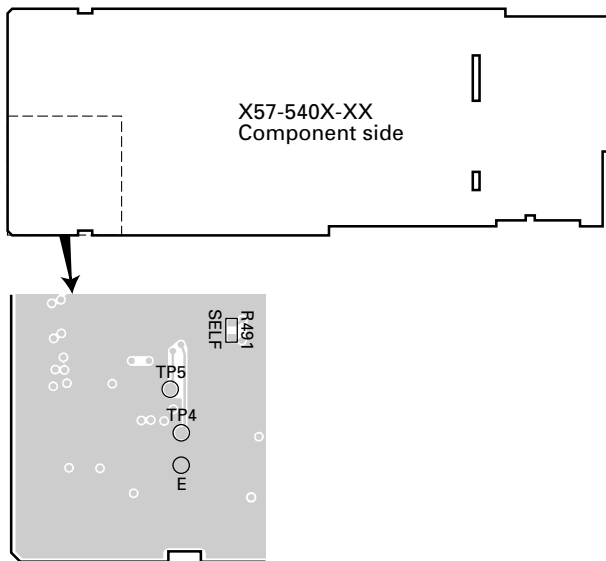

Fig. 6

When enter the self programming mode, "FUNC" appears after "SEL" is displayed for half a second.

Selecting any of Channel setting, Group setting, Function setting, or Clone master with the [Top 1] [Top 2] keys and then pressing [PTT] sets the Setting mode for that time.

Key operations in Self programming mode are as follows.

- [Selector switch] : Not used
- [PTT] : Functions as a RUN or Execute key
- [Top 1] : Use as a Down key
- [Top 2] : Use as an Up key
- [Side 1] : Use for select channel steps in Channel setting mode, or switching for QT/DQT.
- [Side 2] : Use as a cancel key
- [Orange] : Add or delete frequencies in Channel setting mode
- [Toggle] : Flipping this to the right while in Channel setting mode, shifts to MHz steps.

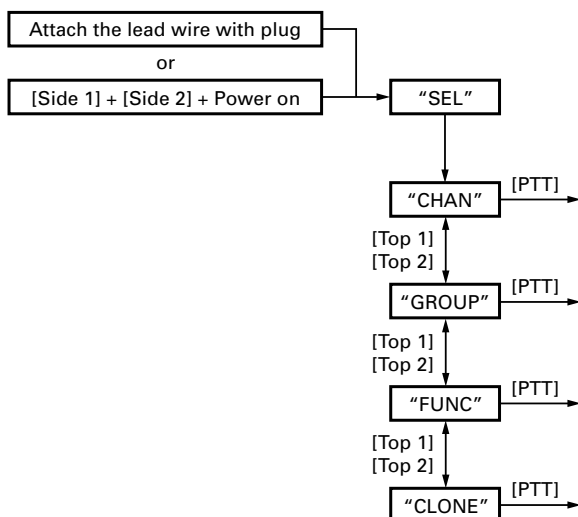

3-2. Channel Setting Mode

Set data for each channel while in this mode. After first entering Self programming mode, select the "CHAN" display with [Top 1] [Top 2] and press [PTT] to set Channel Setting mode. Once in Channel Setting mode, select the group that needs setting with the [Top 1] [Top 2] keys and press [PTT]. Next select the channel for setting with the [Top 1] [Top 2] keys and press [PTT]. The setting items and setting data will then appear so reset the data with the [Top 1] [Top 2] keys and press [PTT]. When finished, the display shifts to the next setting item. After finished setting all items press [PTT] to return to Group selection. Changes in the frequency CH steps and the QT/DQT steps can be made in [Side 1].

No.	Function name	Display	Remarks
	Select Group/Channel	1.-1 during group selection 1-1. during channel selection	1-160~160-1
1	RX frequency	R450.0125	Receive frequency
2	RX signalling	RX 023N	Receive QT/DQT (Dot on right edge is lit up during 1 step changes)
3	TX frequency	T450.0125	Transmit frequency
4	TX signalling	TX 250.3	Transmit QT/DQT (Dot on right edge is lit up during 1 step changes)
5	Option signalling	2ToneA	OFF, DTMF, 2ToneA, 2ToneB, 2ToneC
6	DEL/ADD	D/A ADD	Delete, Add
7	Wide/Narrow	WIDE	Wide, Narrow
8	PTT ID	ID OFF	OFF, ON
9	TX power	POW HI	High, Low
10	Busy channel lockout	BCL OFF	OFF, ON
11	Beat shift	SFT OFF	OFF, ON

• Channel step display

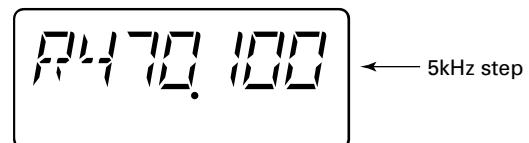

REALIGNMENT

• Operation

1. Select the setting value with the [Top 1] [Top 2] keys.
2. Press the [PTT] and the selected value is backed up and operation shifts to the next item for setting.
3. Press [Side 2] on the Group selection screen in order to return to Self programming mode.

• Note

1. Different sample displays are shown.
2. Setting item No.s are displayed with a 7-segment 2-digit figure on the LCD.
3. Self programming mode cannot be set when set to Disaable with the FPU.
4. A red LED lights up during TX frequency and TX signalling.
5. Press [Orange] on the TX, RX frequencies setting screen in order to clear in the channel frequencies data.
6. Press [Orange] on the signalling setting screen in order to change or off the signalling function.
7. Flipping [Toggle] to the right during setting of RX, TX frequencies and performing Up/Down operation allows frequencies to be changed in MHz steps.
8. The RX and TX frequencies can be entered with the number pad keys.

• Flow Chart

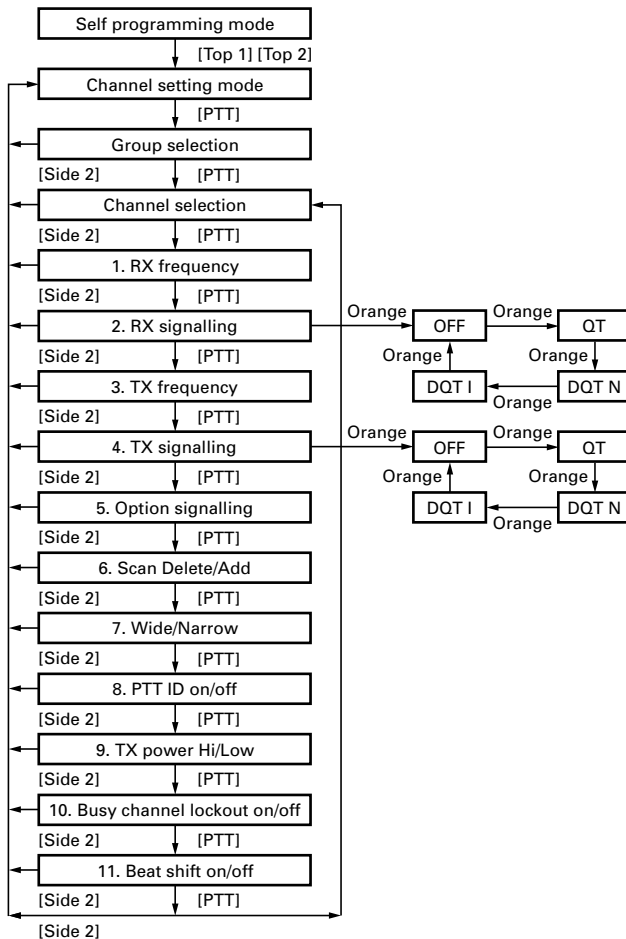

3-3. Group Setting Mode

Set data for each Group while in this mode. After first entering Self programming mode, select the "GROUP" display with [Top 1] [Top 2] and press [PTT] to set Group Setting mode. Once in Group Setting mode, select the group that needs setting with the [Top 1] [Top 2] keys and press [PTT]. Next select the channel for setting with the [Top 1] [Top 2] keys and press [PTT]. The setting items and setting data will then appear so reset the data with the [Top 1] [Top 2] keys and press [PTT]. When finished, the display shifts to the next setting item. After finished setting all items press [PTT] to return to next Group selection.

No.	Function name	Display	Remarks
	Select Group	GRP 1	1~160
1	Battery save	BATT L	OFF, Short, Mid, Long
2	Time out timer	TOT 60	OFF, 30s~300s (30s step)
3	TOT pre alert	TOT.P 10	OFF, 1s~10s (1s step)
4	TOT rekey time	TOT.K 2	OFF, 1s~60s (1s setp)
5	TOT reset time	TOT.S 2	OFF, 1s~15s (1s step)
6	Group Delete/Add	D/A ADD	Delete, Add
7	Signalling	SIG AND	AND, OR

• Operation

1. Select the setting value with the [Top 1] [Top 2] keys.
2. Press the [PTT] and the selected value is backed up and operation shifts to the next item for setting.
3. Press [Side 2] on the Group selection screen in order to return to the Self programming mode initial display.

• Note

1. Different sample displays are shown.
2. Setting item No.s are displayed with a 7-segment 2-digit figure on the LCD.
3. Self programming mode cannot be set when set to Disaable with the FPU.

• Flow Chart

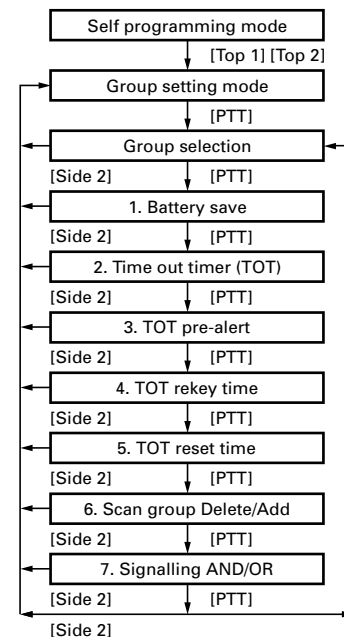

REALIGNMENT

3-4. Function Setting Mode

This mode allows making function settings for the transceiver. After first entering Self programming mode, select "FUNC" display with [Top 1] [Top 2] and then press [PTT] to set this mode. Function setting items are listed below.

No.	Function name	Display	Remarks
1	Power on tone	POW.T 15 (or C)	Continuas, 0~31
2	Control tone	CON.T 15 (or C)	Continuas, 0~31
3	Warning tone	WAR.T 15 (or C)	Continuas, 0~31
4	Alert tone	ALR.T 15 (or C)	Continuas, 0~31
5	Minimum volume	MIN.V 8	0~31
6	Battery warning	BATT ON	Disable, Enable
7	Busy LED	B.LED ON	OFF, ON
8	TX LED	T.LED ON	OFF, ON
9	Invert Display	LCD ON	Disabel, Enable
10	Priority 1	P1 NONE	None, Selected, Fixed
11	Priority 1 group	1.-1	1~1~10~16
12	Priority 1 channel	1-1.	(Priority 1= In fixed)
13	Priority 2	P2 NONE	None, Selected, Fixed
14	Priority 2 group	1.-1	1~1~10~16
15	Priority 2 channel	1-1.	(Priority 2= In fixed)
16	Revert channel	REVT 1	1~8 1 : Selected 2 : Last called 3 : Last used 4 : Sel+Talk back 5 : Priority 1 6 : Priority 1+Talk back 7 : Priority 2 8 : Priority 2+Talk back
17	Squelch level	SQ.LV 15	0~15

• Operation

1. Select the setting value with the [Top 1] [Top 2] keys.
2. Press the [PTT] and the selected value is backed up and operation shifts to the next item for setting.
3. Press [Side 2] on the Group selection screen in order to return to the Self programming mode initial display.

• Note

1. Different sample displays are shown.
2. Setting item No.s are displayed with a 7-segment 2-digit figure on the LCD.
3. Self programming mode cannot be set when set to Dis-able with the FPU.

• Flow Chart

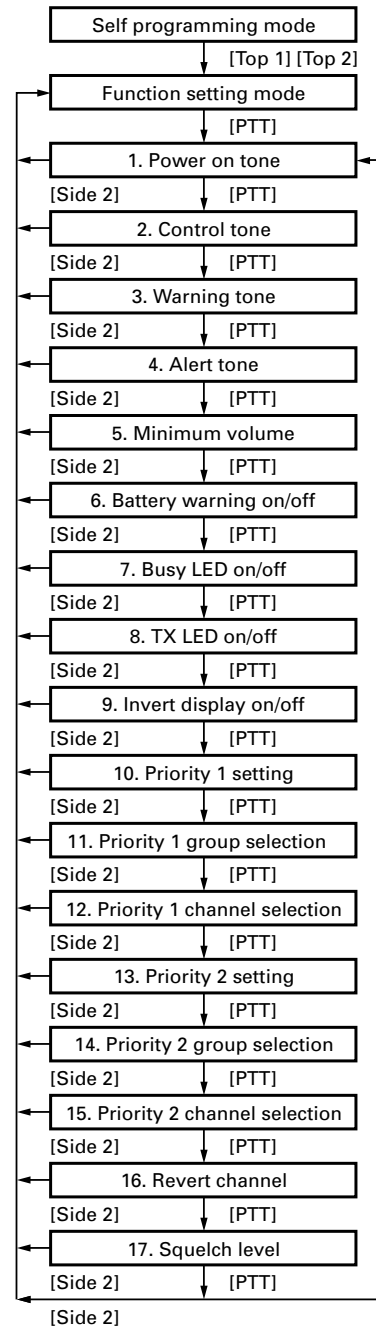

REALIGNMENT

3-5. Clone Mode

1. Connect the cloning interface cable between the master side transceiver (source) and slave side transceiver (clone) as shown in the figure.

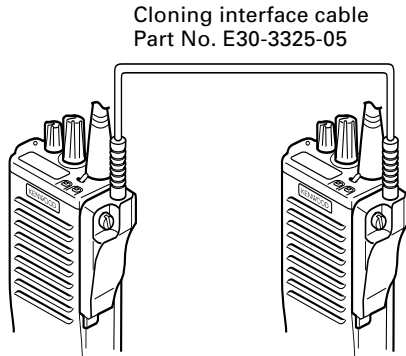

2. Set the master side transceiver to Self programming mode, and the transceiver display to "CLONE" with the [Top 1] key or [Top 2] key and press [PTT].

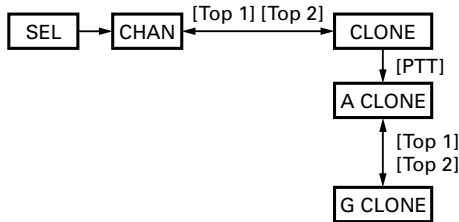

3. Set the power switch on the slave side transceiver to ON.
4. The red LED on the master side transceiver flashes when cloning starts and an "END" message appears when cloning ends.
5. The green LED on the slave side transceiver flashes.
6. When a problem occurs during cloning, an "ERROR" message appears on the master side transceiver.
7. Pressing the [Side 2] key sets clone mode.

Note :

The master transceiver copies only to type matched slave.

• All Clone

1. Press [PTT] on the master side transceiver to start cloning of all data except for the transceiver model type and alignment data.

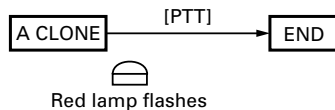

• Group Clone

1. To clone the transceiver group data and channel data within the group, as well as group alphanumeric data, use the [Top 1] key or [Top 2] key to switch the display on the master side transceiver from "A CLONE" to "G CLONE".

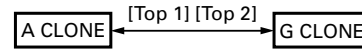

2. Press [PTT] to show the group cloning selection.
3. Select the group with the [Top 1] or [Top 2] keys.
4. Press [PTT] to show the slave side group cloning selection.
5. Select the group with the [Top 1] or [Top 2] keys.



6. Press the master side [PTT] to start cloning.

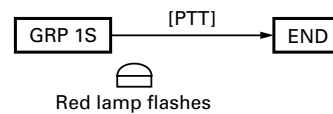

• Flow Chart

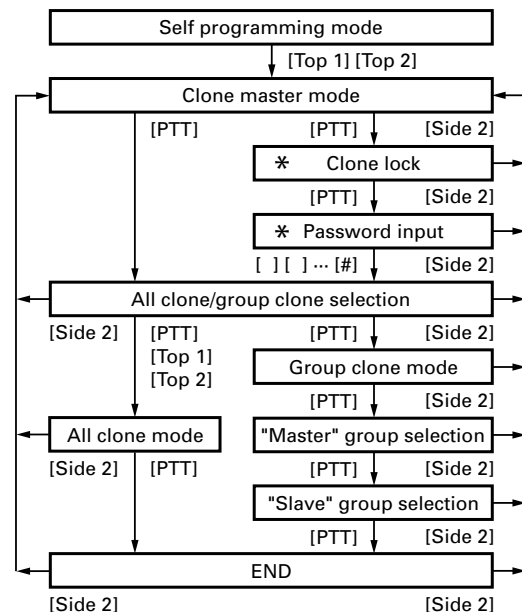

REALIGNMENT

4. Firmware Programming Mode

4-1. Preface

Flash memory is mounted on the TK-390. This allows the TK-390 to be upgraded when new features are released in the future. (For details on how to obtain the firmware, contact Customer Service.)

4-2. Connection Procedure

Connect the TK-390 to the personal computer (IBM PC or compatible) with the interface cable (KPG-36). (Connection is the same as in the PC Mode.)

4-3. Programming

1. Start up the programming software (KPG-38D), select "firmware program" in the "Program" item, and press the Return key on the personal computer. This starts up the firmware programmer.
2. The top screen is displayed. Press any key to advance to the next screen.
3. Set the communications speed (normally, 38400 bps) and communications port in the Setup item.
4. Set the firmware to be updated by File select.
5. Held down the [Side 2] and [PTT]. Turn the TK-390 power on, and release [Side 2] first. Until the display change to "PROGRAM".
6. Check the connection between the TK-390 and the personal computer, and make sure that the TK-390 is in the Program mode.
7. Press F10 on the personal computer. A window opens on the display to indicate progress of writing. When the TK-390 starts to receive data, "PG" is appeared on 2 digit sub display.
8. If writing ends successfully, the red LED on the TK-390 lights and the checksum is displayed.
9. If you want to continue programming other TK-390s, repeat steps 5 to 8.

Notes :

- To start the Firmware Programmer from KPG-38D, the Fpro path must be set up by KPG-38D setup.
- This mode cannot be entered if the Main Program mode is set to Disable in the Programming software (KPG-38D).

4-4. Function

1. If you press the [Top 2] switch while "PROGRAM" is displayed, the checksum is displayed. If you press the [Top 1] switch while the checksum is displayed, "PROGRAM" is redisplayed.
2. If you press the [Top 1] switch while "PROGRAM" is displayed, 1 dot light ("M.") to indicate that the write speed is low-speed (19200 bps). If you press the [Top 1] switch again while low-speed (19200 bps), 2 dot lights (".M.") to indicate, and the write speed becomes the high-speed mode (38400 bps).
The communication speed changes 19200 bps, 38400 bps, 57600 bps (3 dots), and 115200 bps (4 dots) every time you press [PTT] and [Top 1].

Note :

Normally, write in the high-speed mode.
When the Flash ROM is replaced, the initial communication speed for writing becomes 115200 bps.

5. Panel Test Mode

Setting method refer to ADJUSTMENT.

CIRCUIT DESCRIPTION

1. Overview

The KENWOOD model TK-390 is a UHF/FM hand-held transceiver designed to operate in the frequency range of 403 to 512MHz, the unit consists of a receiver, a transmitter, a phase-locked loop (PLL) frequency synthesizer, power supply circuits, a control unit.

2. Circuit Configuration by Frequency

The receiver is a double-conversion superheterodyne with a first intermediate frequency (IF) of 44.85MHz and a second IF of 455kHz. Incoming signals from the antenna are mixed with the local signal from the PLL to produce the first IF of 44.85MHz.

This is then mixed with the 44.395MHz second local oscillator output to produce the 455kHz second IF. This is detected to give the demodulated signal.

The transmit signal frequency is generated by the PLL VCO, and modulated by the signal from the microphone. It is then amplified and sent to the antenna.

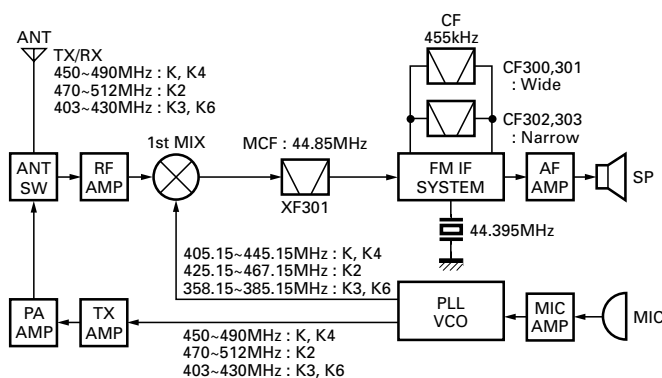

Fig. 1 Frequency configuration

3. Receiver System

3-1. Front-end RF amplifier

The signal coming from the antenna passes through the transmit/receive switching diode circuit, is amplified by the RF amplifier (Q200), and passes through a BPF (L205). The resulting signal is further amplified by the RF amplifier (Q201), passes through a BPF (L210) and goes to the mixer. The band-pass filters (L205 and L210) are two-pole helical resonators that uses varactor diode tuning to reject unwanted signal components.

3-2. First mixer

The 1st mixer uses the GaAs IC (IC200). The 1st mixer mixes the signal with the 1st local oscillator frequency from the VCO, and converts it to the 1st IF (44.85MHz).

The signal then passes through monolithic crystal filter (XF301) to remove unnecessary nearby frequency components. The signal from the MCF is used as the 1st IF signal.

3-3. IF amplifier

The 1st IF signal is amplified (Q302) and fed into IC300 in the FM IF IC. The IF signal is then mixed with the 2nd local oscillator frequency of 44.395MHz to generate the 2nd IF of 455kHz. The 455kHz signal is then passed through a ceramic filter (CF300, CF301 ; Wide, CF302, CF303 ; Narrow) and fed back into IC300 for additional amplification.

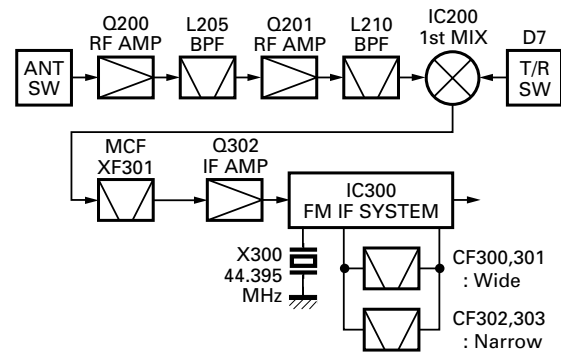

Fig. 2 Receiver section

Item	Rating
Nominal center frequency	44.85MHz
Pass band width	$\pm 5\sim 7$ kHz at 3dB
Attenuation band width	± 25 kHz or less at 30dB
Ripple	1.0dB or less
Insertion loss	4dB or less
Guaranteed attenuation	80dB or more at $f_0 \pm 910$ kHz 40dB or more within $f_0 \pm 1$ MHz
Terminating impedance	350 Ω / 4.5pF

Table 1 Crystal filter XF301 (L71-0588-05)

CIRCUIT DESCRIPTION

3-4. Wide/Narrow changeover circuit

Narrow and Wide settings can be made for each channel by switching the ceramic filters CF300, CF301 (Wide), CF302, CF303 (Narrow).

The WIDE (high level) and NARROW (low level) data is output from IC400 (I/O port expansion) pin 4.

When a WIDE (high level) data is received, Q300, Q303 turn off and Q304 turn on. When a NARROW (low level) data is received, Q303 turn on and Q301, Q304 turn off. D302, D303 are switched to ceramic filters when a high/low level data is received.

Q305 turns on/off with the Wide/Narrow data and the IC300 detector output level is changed to maintain a constant output level during wide or narrow signals.

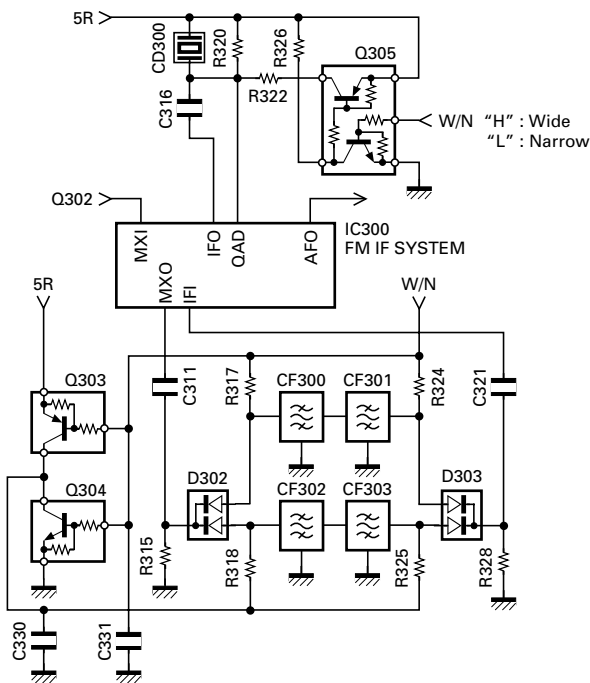

Fig. 3 Wide/Narrow changeover circuit

3-5. Audio amplifier circuit

• TX-RX unit

The demodulated signal from IC300 goes through IC301, and is amplified by IC601 (2/2), high-pass filtered, low-pass filtered, high-pass filtered, band-eliminate filtered, and de-emphasized by IC607.

The signal then goes through an electronic volume control (IC603), an AF amplifier IC604 (2/2), and an AF switch (Q8 is on and Q7 is on of the control unit), and is routed to audio power amplifier (IC1 of the control unit), where it is amplified and output to the internal speaker.

• Control unit

The audio mute signal (AMP SW) from the microprocessor becomes Low in the standby and Q5, Q6 which are power supply circuit for IC1 turn off. When the audio is output, AMP SW becomes High to turn Q5, Q6 on, and voltage is supplied to power terminal VP of IC1.

Speaker switching is done from IC403 (TX-RX unit) by INT AFC or EXT AFC. First, the logic level at the speakers switching terminal (SSW) on the universal connector is input to the microprocessor (IC406 TX-RX unit). The microprocessor then outputs data to IC403 based on this input.

When there is no SP-MIC installed, this logic level is high. When the INT AFC is high, the EXT AFC goes low, so the AF signal is only input to the amplifier for the internal speaker (INT SP) of IC1. However, when a SP-MIC has been installed, this logic level is low, so the INT AFC goes low and the EXT AFC goes high. So that the AF signal is input only to amplifier for the external speaker (EXT SP) of IC1.

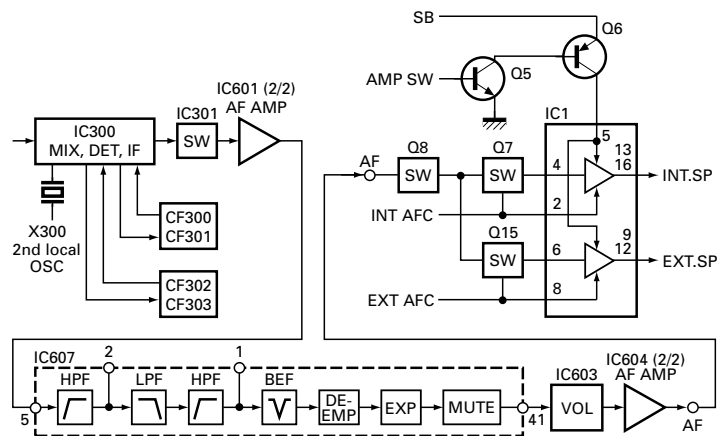

Fig. 4 Audio amplifier circuit

3-6. Squelch circuit

It amplifies the demodulated noise signal from FM IC (IC300) after filtering through BPF circuit. Then, the amplified signal is converted to DC signal by the detection circuit. The converted signal is fed through the microprocessor (IC 406) and the voltage level is detected by ADC (A/D converter) to control the squelch circuit.

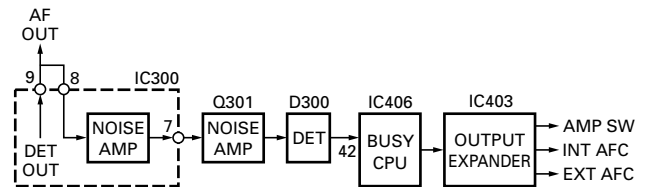

Fig. 5 Squelch circuit

CIRCUIT DESCRIPTION

4. Transmitter System

4-1. Microphone amplifier

The signal from IC3 (control unit) goes through the mute switch (Q403).

When the SP-MIC is not attached, the microphone switching terminal (MSW) on the universal connector becomes High, and mute switch (Q403) is turned on. When the SP-MIC is attached, MSW is connected to GND at inside of SP-MIC. For this reason, Q403 is turned off, the internal microphone is muted, and only the input of the external microphone is supplied to the microphone amplifier of the TX-RX unit.

The signal from microphone passes through the limiter circuit in D601, and through the high-pass filter, the ALC circuit, the low-pass filter, the high-pass filter, and pre-emphasis/IDC circuit in IC607. When encoding DTMF, mute switch (Q601) is turned off for muting the microphone input signal.

The signal passes through the D/A converter (IC603) for the maximum deviation adjustment, and enters the summing amplifier consisting of IC605 (1/2), and is mixed with the low speed data from the CPU (IC406).

The output signal from the summing amplifier goes to the VCO modulation input.

The other output signal from the summing amplifier passes through the D/A converter (IC603) again for the BAL adjustment, and the buffer amplifier (IC604 1/2), and goes to the VCXO modulation input.

4-2. Noise cancelling microphone circuit

The two signals from INT MIC (Main & Sub) are input to the positive (+) input (Sub) and to the negative (-) input (Main) of the IC3. If the same signal is input to both Main and Sub, the Main signal is canceled at the output of IC3 (pin 7). In other words, noise from nearby sources not directly connected to the transceiver enters the Main and Sub inputs at the same signal and is therefore canceled out.

When a signal is only input to Main and there is no signal at Sub, the Main signal is output as is, from IC3 (pin 7). In other words, only the voice audio of the operator in extremely close proximity to the Main MIC is input to Main so that the signal is output as is from IC3 (pin 7). Also, when the "N/C" switch is set to "L", transistor Q14 turns off so Sub microphone turns off and operation is the same as above.

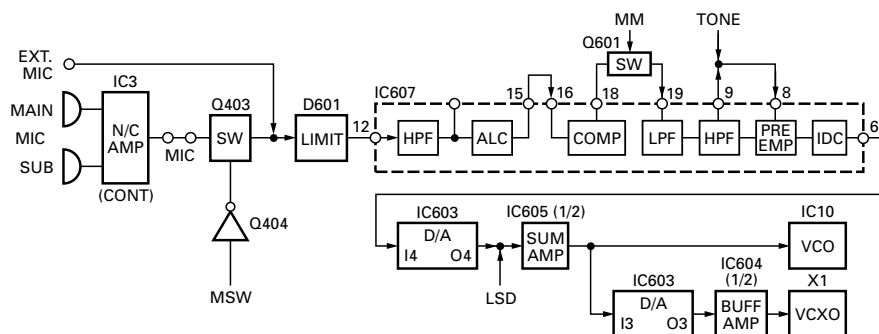

Fig. 6 Microphoen circuit

4-3. Drive and Final amplifier

The signal from the T/R switch (D7 is on) is amplified by the pre-drive (Q6) and drive amplifier (Q8) to 20mW. The output of the drive amplifier is amplified by the RF power amplifier (IC501 or IC801) to 4W (1W when the power is low).

The RF power amplifier consists of two stages MOS FET transistor. The output of the RF power amplifier is then passed through the Transmit-Receive (TX-RX) antenna switching (D10 is on) and the harmonic filter (LPF) and the Internal-External (INT-EXT) antennal switching (in the universal connector) and applied to the antenna terminal.

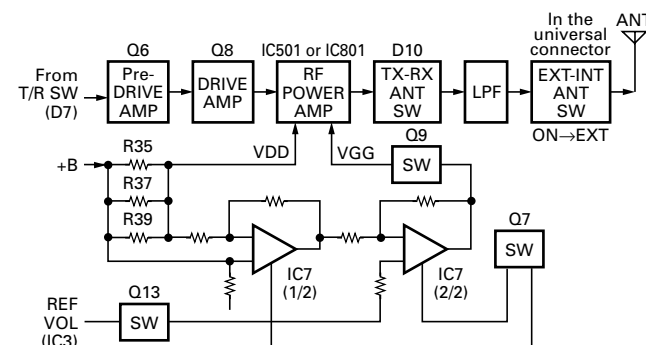

Fig. 7 Drive and final amplifier and APC circuits

4-4. Internal-External (INT-EXT) antenna switching

The INT-EXT antenna switch housed inside the universal connector only switches to the EXT ANT side when an antenna speaker-microphone has been installed.

This INT-EXT antenna switch works mechanically and switches based on the operation shown in Figure 8.

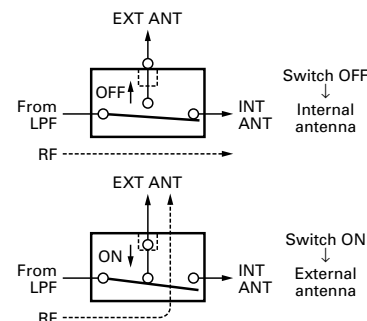

Fig. 8 Internal-External antenna switching

CIRCUIT DESCRIPTION

4-5. APC circuit

The APC circuit always monitors the current flowing through the RF power amplifier (IC501 or IC801) and keeps a constant current. The voltage drop at R35, R37, and R39 is caused by the current flowing through the RF power amplifier and this voltage is applied to the differential amplifier (IC7 1/2).

IC7 (2/2) compares the output voltage of IC7 (1/2) with the reference voltage from IC3, and the output of IC7 (2/2) controls the VGG of the RF power amplifier to make the both voltages to same voltage.

The change of power high/low is carried out by the change of the reference voltage. Q7, Q9, and Q13 are turned on in transmit and the APC circuit is active. (See Figure 7)

5. PLL Frequency Synthesizer

The frequency synthesizer consists of the VCXO (X1), VCO (IC10 or L800), PLL IC (IC5) and buffer amplifiers.

The VCXO generates 16.8MHz. The frequency stability is within 2.0ppm (temperature range of -30 to $+60^{\circ}\text{C}$). The frequency tuning and modulation of the VCXO are done to apply a voltage to pin 1 of the VCXO. The output of the VCXO is applied to pin 8 of the PLL IC.

The VCO of TK-390 covers the 40MHz spread, setting frequencies in r1, r2 (receive) and t1, t2 (transmit) with a bias voltage applied to the $-V$ terminal of the VCO. A zero (0) volt bias is applied at frequencies lower than r1, t1. Frequencies r1, t1 through r2, t2 are biased with -3 volts. Frequencies higher than r2, t2 are biased with -6 volts.

The relation of VCO frequency versus PLL lock voltage is shown in Figure 11.

The output of the VCO is amplified by the buffer amplifier (Q3) and routed to the pin 5 of the PLL IC. Also the output of the VCO is amplified by the buffer amplifier (Q5) and routed to the next stage according to T/R switch (D7).

The PLL IC consists of a prescaler, fractional divider, reference divider, phase comparator, charge pump. This PLL IC is fractional-N type synthesizer and performs is the 40 or 50kHz reference signal which is eighth of the channel step (5 or 6.25kHz). The input signal from the pins 1 and 5 of the PLL IC is divided down to the 40 or 50kHz and compared at phase comparator. The pulsed output signal of the phase comparator is applied to the charge pump and transformed into DC signal in the loop filter (LPF). The DC signal is applied to the pin 4 of the VCO and locked to keep the VCO frequency constant.

PLL data is output from DT (pin 85), CLK (pin 84) and LE (pin 93) of the microprocessor (IC406). The data are input to the PLL IC when the channel is changed or when transmission is changed to reception and vice versa. A PLL lock condition is always monitored by the pin 30 (UL) of the microprocessor. When the PLL is unlocked, the UL goes low.

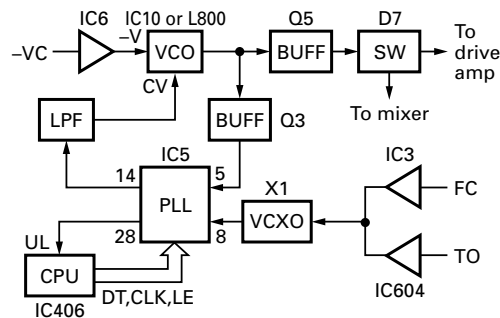

Fig. 9 PLL block diagram

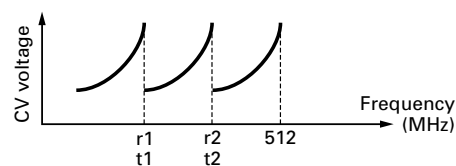

Fig. 10 CV voltage vs frequency

6. Power Supply Circuit

Battery +B is supplied via a 3A fuse from the battery terminal connected to the TX-RX unit. After passing through the power switch power supply (SB) is applied to the two AVR ICs, and AVR circuit.

IC401 supplies 5V (5CM) to the control circuit. IC402 supplies 5V (5M) to the common circuit.

AVR circuit (Q400, Q402, Q405, Q406) supplies voltage to the TX circuit and the RX circuit. 5C is common 5V and output when SAVE is not set at off. 5R is 5V for reception and output during reception. 5T is 5V for transmission and output during transmission.

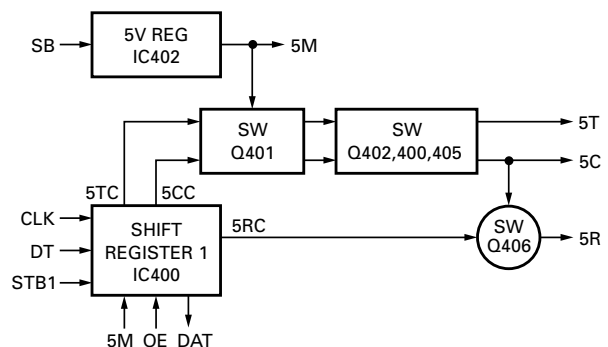

Fig. 11 Power supply circuit

CIRCUIT DESCRIPTION

7. Control Circuit

The control unit consists of microprocessor IC406, flash memory IC414, and its peripheral circuits. It controls the TX-RX unit and transfers data to and from the control unit. The CPU (IC406) mainly performs the following :

- 1) Switching between transmission and reception by PTT signal input.
- 2) Reading channel, frequency, and program data from the memory circuit.
- 3) Sending frequency program data to the PLL.
- 4) Controlling squelch on/off by the pulse signal input from the squelch circuit.
- 5) Controlling the audio mute circuit by decode data input.
- 6) Transmitting encode data (QT, DQT).
- 7) Sending serial data to output expander (IC400, IC403, IC404 and IC405) to control various function in the unit.

7-1. Memory circuit

IC414 is a flash memory with a capacity of 2M bits that contains the transceiver control program for the CPU and data such as transceiver channels and operating features.

This program can be easily written from an external devices. Data, such as DTMF memories and operating status, are programmed into the EEPROM (IC412).

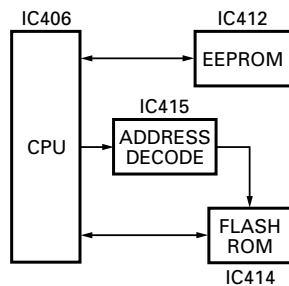

Fig. 12 Memory circuit

7-2. CPU clock shift

When the CPU (IC406) 12MHz clock (X400) high frequency is multiplexed with the reception frequency, it becomes an internal beat signal, suppressing the signal sensitivity. To prevent this, by turning Q407 on, the clock frequency is shifted (about 4kHz).

(Shift on/off can be set through programming.)

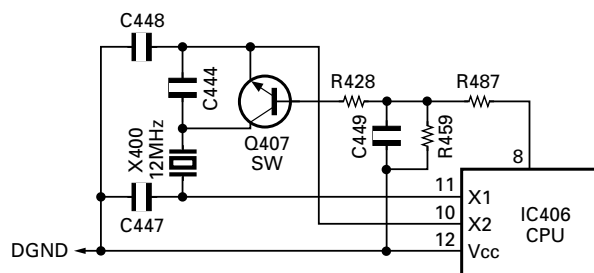

Fig. 13 CPU clock frequency shift

7-3. Shift register

IC400, 403, 404 and 405 is an interface IC for output port expansion. It is used to expand the CPU (IC406) output ports.

7-4. D/A converter

IC3 and IC603 is used as a conventional semi-fixed-resistor converter. It sets the following :

- 1) RX sensitivity
- 2) Transmission power
- 3) Modulation level
- 4) Audio power
- 5) Frequency

7-5. Key input

K11 or K12 becomes HIGH when any key is pressed (or Enable signal on the optional circuit).

When K11 or K12 becomes HIGH, K10 also becomes HIGH to trigger the interrupt to IC406 in order to start the key scan.

When the key scan starts, the output terminals (Q1~Q5) become LOW. Only the key sensing circuit remains HIGH. When a key is pressed, the signal is routed through K11 or K12 to the microprocessor. Then, the microprocessor determines which key is pressed using this signals.

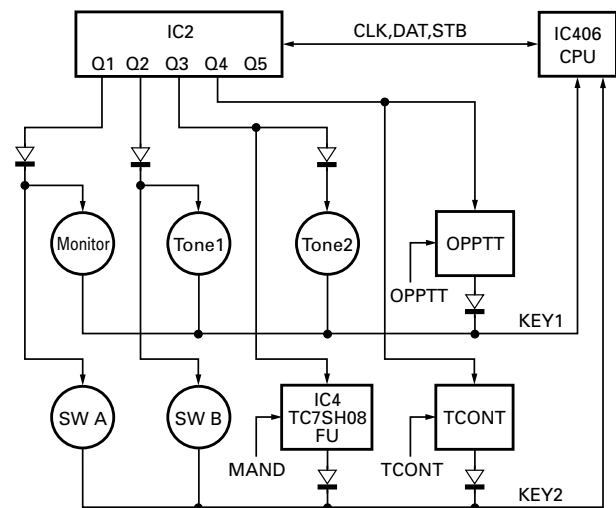

Fig. 14 Key input

CIRCUIT DESCRIPTION

7-6. Low battery warning

The battery voltage is monitored by the microprocessor (IC406). When the battery voltage falls below the voltage set by the Low Battery Warning adjustment, the red LED flashes to notify the operator that it is time to replace the battery. If the battery voltage falls even more (approx. 5.5V), a beep sounds and transmission is stopped.

Low battery warning	Battery condition
The red LED flashes during transmission	The battery voltage is low but the transceiver is still usable
The red LED flashes and continuous beep sounds while PTT pressed.	The battery voltage is low and the transceiver is not usable to make calls.

8. Signalling Circuit

8-1. Encode

The CPU (IC406) transmits the encode data selected by the program.

• Low-speed data (QT, DQT)

Low-speed data is output from pin 34 of the CPU. The signal passes through a low-pass CR filter, and goes to the summing amplifier (IC605 1/2). The signal is mixed with the audio signal and goes to the VCO (IC10) and VCXO (X1) modulation input after passing through the D/A converter (IC603) for BAL adjustment.

• High-speed data (DTMF)

High-speed data is output from pin 35 of the CPU. The signal passes through a low-pass filter consisting of IC413, and provides a TX DTMF tone and a RX DTMF tone including a beep tone. The TX DTMF tone is passed to the D/A converter (IC603) for DTMF deviation adjustment, and then applied to the audio processor (IC607).

The signal is mixed with the audio signal and goes to the VCO and VCXO. The RX DTMF tone is passed the D/A converter (IC603) for audio control, summing amplifier (IC604 2/2), audio power amplifier and then to the speaker.

• MSK

The MSK signal (1200 bps) is output from pin 6 of IC607. The signal passes through the D/A converter (IC603) for the MSK deviation adjustment, and is routed to the VCO.

When encoding MSK, the microphone input signal is muted.

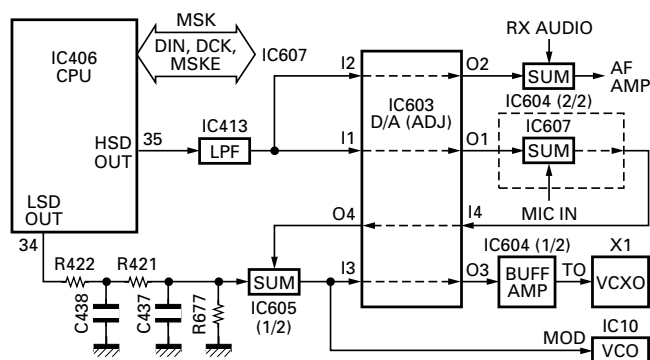

Fig. 15 Encode

8-2. Decode

• Low-speed data (QT, DQT)

The demodulated signal from the FM IF IC (IC300) is amplified by IC601 (2/2) and passes through a low-pass filter (IC602) to remove audio components. The signal is input to pin 28 of the CPU.

The CPU digitizes this signal, performs processing such as DC restoration, and decodes the signal.

• High-speed data (DTMF)

The DTMF input signal from the FM IF IC (IC300) is amplified by IC601 (2/2) and goes to IC600, the DTMF decoder. The decoded information is then processed by the CPU. During transmission and standby, the DTMF IC is set to the power down mode when the PD terminal is High. When the line is busy, the PD terminal becomes Low, the power down mode is canceled and decoding is carried out.

• MSK

The MSK input signal from the IF IC is amplified by IC601 (2/2) and goes to pin 5 of IC607. The signal is demodulated by MSK demodulator in IC607. The demodulated data goes to the CPU for processing.

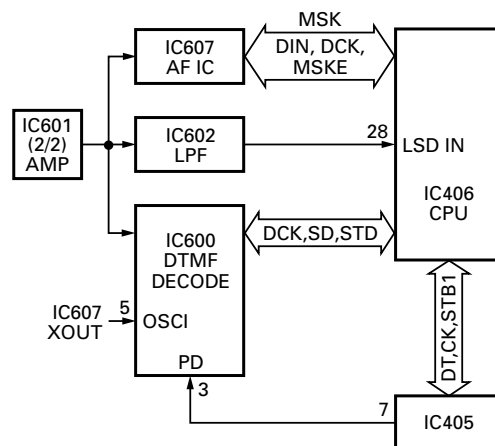

Fig. 16 Decode

CIRCUIT DESCRIPTION

9. Componder Circuit

The term compander is a compound of compressor and expander. The compander reduces noise by utilizing a compressor and an expander.

As shown in Fig. 17, the signal input to the compressor is compressed so that the logarithmic ratio is 1/2 with reference to -10dBV , and then output onto the transmission path. The signal is expanded by the expander so that the logarithmic ratio is 2 with reference to -10dBV . This reduces noise on the transmission path and prevents deterioration of the signal quality due to noise during transmission.

The TK-390 contains IC607 (TC35453F) to perform this operation.

- Pin 16 : Compressor input pin
- Pin 18 : Compressor output pin
- Pin 43 : Expander input pin
- Pin 41 : Expander output pin

The TK-390 compander can be turned on or off only when modulation is set to Narrow by FPU setting. The compander cannot be turned on when modulation is set to Wide (OFF).

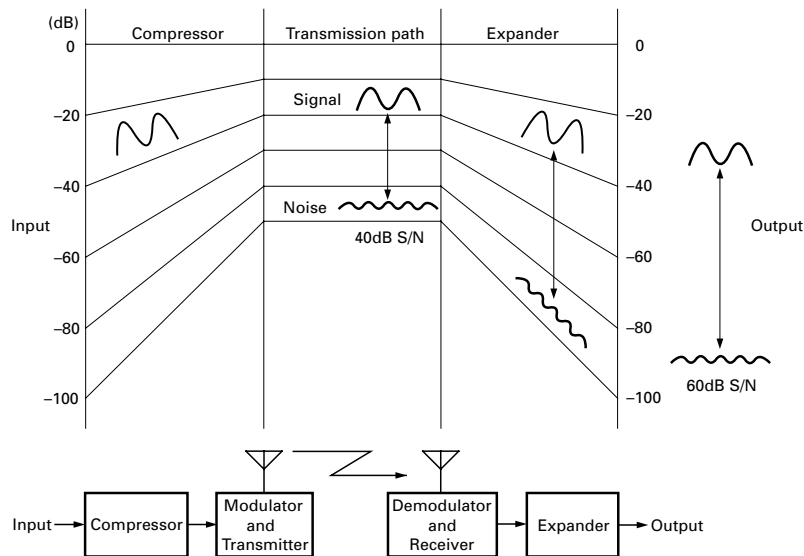

Fig. 17

10. Option Board Terminal

Terminals for mounting the option board are provided at the bottom of the TX-RX unit. The table below shows the correspondence between the board and terminals. Disconnect R414 and R665 in TX-RX unit when the scrambler board is attached.

Connect the option board to the connection terminals of the TX-RX unit.

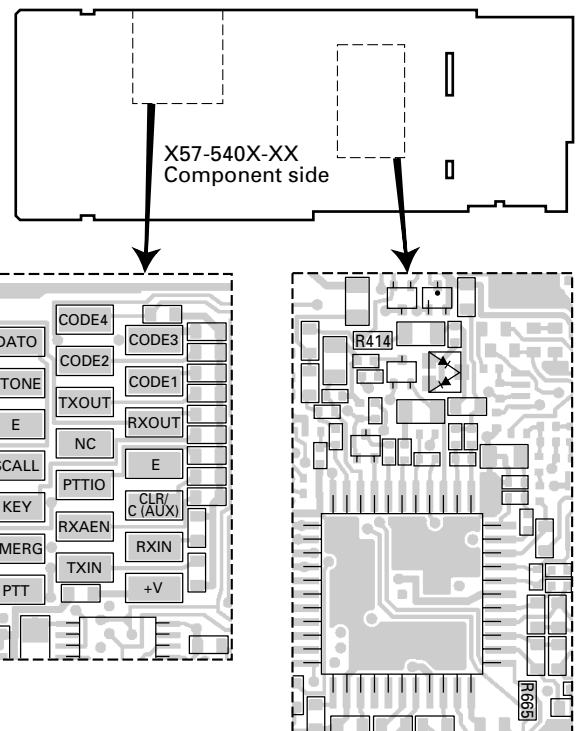

Fig. 18

CIRCUIT DESCRIPTION

10-1. Option port 1 (For ANI board etc.)

Port name		Description	Connection	Note
Abbreviation (PCB)	Name			
DATI	Data In	Board data input Transceiver (Receiver demodulation circuit) → ANI board	Connected to the circuit	Reference 1kHz STD Dev → 250~350mVrms
DATO	Data Out	Board data output ANI board → Transceiver (Transmitter modulation circuit)	Connected to the circuit	Reference 1kHz/150mVrms → 2.5~3.5kHz/wide 1.25~1.75kHz/narrow
TCONT	T Control	Audio amplifier power control → Control unit (X53) counter → TX-RX unit (X57) microcomputer	Microcomputer input	L : Audio amp on H : Audio amp off
STONE	Side Tone	Beep during PTT ID	Connected to the circuit	
AUDIH	Audio Inhibit	Microphone muting during PTT ID	Connected to the circuit	
E	Ground	Ground	Ground	
MUTE	Mute	Mutes transceiver receive tone	Connected to the circuit	
SCALL	Selective Call	LED drive port for selective call	Unused, no connection	
AUX	Aux	Emergency Channel request → Control unit (X53) counter → TX-RX unit (X57) microcomputer	Microcomputer input	L : EMG CH request H : No EMG CH request
PTT	PTT	Microcomputer PTT logic → ANI board	Microcomputer output	L : TX, H : RX
MAND	Man Down	Man Down mercury switch input port Transceiver → ANI board	Microphone connector	L : Switch on H : Switch off
EMERG	Emergency	Microcomputer Emergency Channel logic → ANI board	Microcomputer output	L : Emergency operation request H : No emergency operation request
BUSY	Channel Busy	Microcomputer Busy logic → ANI board	Microcomputer output	L : Busy H : Not busy
KEY	(Transmission) Key	Transmission start control GE-Star → Control unit (X53) counter → TX-RX unit (X57) microcomputer	Microcomputer input	L : Transmission request H : No transmission request
A+	Board power supply	Switched B	Power supply	

10-2. Option port 2 (For voice scrambler etc.)

Abbreviation (PCB)	Name	Description	Check mode operation	Note
CODE1	Scramble Code 1	First of four bits of scramble code	Microcomputer output	Board code selection (Logic by binary code)
CODE2	Scramble Code 2	Second of four bits of scramble code		
CODE3	Scramble Code 3	Third of four bits of scramble code		
CODE4	Scramble Code 4	Fourth of four bits of scramble code		
TXOUT	TX Out	Board → Transceiver (Transmitter modulation circuit)	Connected to the circuit	Reference 1kHz/15mVrms → 2.5~3.5kHz/wide 1.25~1.75kHz/narrow
RXOUT	RX Out	Board → Transceiver (Audio amp)	Connected to the circuit	
NC	No Connection	No connection	No connection	
E	Ground	Ground	Ground	
PTTIO		Scramble modulation/demodulation control	Microcomputer output	L : TX, H : RX
CLR/C (AUX)	Clear/Code	Specifies whether to scramble	Microcomputer output	L : Scramble H : Normal
RXAEN		Enables the power save mode of the board	Microcomputer output	L : Power save mode H : Normal
RXIN	RX In	Transceiver (Receiver detection output) → Board	Connected to the circuit	Reference 1kHz STD Dev → 250~350mVrms
TXIN	TX In	Transceiver (Microphone circuit) → Board	Connected to the circuit	
+V	Board power supply	Switched B	Power supply	

SEMICONDUCTOR DATA

1. Microprocessor : 784214GC0648EU (TX-RX Unit IC406)

1-1. Terminal function

Pin No.	Port name	I/O	Function	Pin No.	Port name	I/O	Function
1	P120/RTP0	O	Modem FCLR	50	P82/A2	–	Flash ROM access port.
2	P121/RTP1	O	SB control	51	P83/A3	–	
3	P122/RTP2	O	D/A converter CS	52	P84/A4	–	
4	P123/RTP3	O	Modem MSKE (MSK enable)	53	P85/A5	–	
5	P124/RTP4	O	Modem DIN (DATA/TX DATA)	54	P86/A6	–	
6	P125/RTP5	I	Model select 1	55	P87/A7	–	
7	P126/RTP6	I	Model select 2	56	P40/AD0	–	
8	P127/RTP7	O	Clock shift	57	P41/AD1	–	
9	VDD	–	+5V	58	P42/AD2	–	
10	X2	–	X'tal (12.0MHz)	59	P43/AD3	–	
11	X1	–					
12	VSS	–	GND	60	P44/AD4	–	
13	XT2	–	Open	61	P45/AD5	–	
14	XT1	–	GND	62	P46/AD6	–	
15	RESET	–	CPU reset	63	P47/AD7	–	
16	P00/INTP0	I	μ-com stop	64	P50/A8	–	
17	P01/INTP1	I	Modem TRD (TX clock)	65	P51/A9	–	
18	P02/INTP2/NMI	I	Modem RTM (RX clock)	66	P52/A10	–	
19	P03/INTP3	I	DTMF decode STD	67	P53/A11	–	
20	P04/INTP4	I	Key interrupt	68	P54/A12	–	
21	P05/INTP5	I	Power switch detect	69	P55/A13	–	
22	P06/INTP6	I	MIC PTT	70	P56/A14	–	
23	AVDD	–	+5V	71	P57/A15	–	
24	AVREF0	–	+5V	72	VSS	–	GND
25	P10/ANI0	I	Volume level input	73	P60/A16	–	Flash ROM access port
26	P11/ANI1	I	SP key 1/2	74	P61/A17	–	
27	P12/ANI2	I	(Temp)	75	P62/A18	–	Flash ROM (4M bit) access port.
28	P13/ANI3	I	QT/DQT input	76	P63/A19	–	Open
29	P14/ANI4	I	Battery level input	77	P64/RD	–	Flash ROM access port.
30	P15/ANI5	I	PLL unlock detect input	78	P65/WR	–	
31	P16/ANI6	I	*SQL level input	79	P66/WAIT	I	TX Inhibit (Radio kill)
32	P17/ANI7	I	*RSSI level input	80	P67/ASTB	–	Open
33	AVSS	–	GND	81	VDD	–	+5V
34	P130/ANO0	O	LSD (QT/DQT) output	82	P100/TI5/TO5	O	EEPROM clock
35	P131/ANO1	O	DTMF/BEEP output	83	P101/TI6/TO6	I/O	EEPROM data
36	AVREF1	–	+5V	84	P102/TI7/TO7	O	Common clock
37	P70/RXD2/SI2	O	Battery DET SW	85	P103/TI8/TO8	O	Common data
38	P71/TXD2/SO2	I	EXT. SP install check (No : H)	86	P30/TO0	O	Shift register output enable
39	P72/ASCK2/SCK2	O	Non connect	87	P31/TO1	I	Key counter return 1
40	P20/RXD1/SI1	I	←FPU	88	P32/TO2	I	Key counter return 2
41	P21/TXD1/SO1	O	→FPU	89	P33/TI1	I	Self program flag (Soft pull up)
42	P22/ASCK1/SCK1	O	Modem STB	90	P34/TI2	O	Key counter enable
43	P23/PCL	O	DTMF clock	91	P35/TI00	I	2-tone decode latch
44	P24/BUZ	I	DTMF decoder SD	92	P36/TI01	I	Digital SQL
45	P25/SI0	O	LCD CS	93	P37	O	PLL LE
46	P26/SO0	O	Shift register 1 STB	94	TEST	–	GND
47	P27/SCK0	O	Shift register 2 STB	95~98	P90~P93	I	Rotary SW 1~4
48	P80/A0	–	Flash ROM access port.	99	P94	I	Toggle SW input
49	P81/A1	–					
				100	P95	I	Modem RDT (RX DATA)

SEMICONDUCTOR DATA / DESCRIPTION OF COMPONENTS

2. RF Power Amplifier (Control Unit IC501)

XHW2727-2 : K,K2,K4

2-1. Block diagram

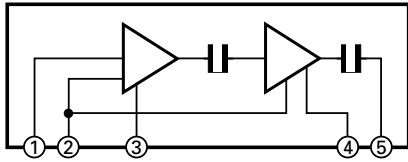

2-2. Maximum ratings (Flange temperature = 25°C)

Rating	Symbol	Value	Unit
DC supply voltage (Pins 3,4)	V _{DD1,2}	10	Vdc
DC control voltage (Pin 2)	V _{cont}	10	Vdc
RF input power	P _{in}	40	dBm
RF output power (V _{DD1,2} =9V)	P _{out}	9	W
Operating case temperature range	T _c	-30 to +100	°C
Storage temperature range	T _{stg}	-30 to +100	°C

3. RF Power Amplifier (Final Unit IC801)

M68732L : K3,K6

3-1. Block diagram

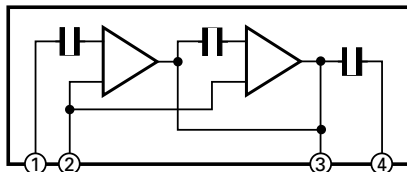

3-2. Maximum ratings (Flange temperature = 25°C)

Rating	Symbol	Value	Unit
DC supply voltage (Pins 3)	V _{DD}	12	Vdc
DC control voltage (Pin 2)	V _{cont}	4	Vdc
RF input power	P _{in}	70	dBm
RF output power	P _{out}	10	W
Operating case temperature range	T _c	-30 to +110	°C
Storage temperature range	T _{stg}	-40 to +110	°C

Final Unit (X45-3590-10) : K3,K6

Ref. No.	Use / Function	Operation / Condition
IC801	RF power amplifier	

Control Unit (X53-3930-XX)

-13 : K,K2 -14 : K4 -15 : K3 -16 : K6

Ref. No.	Use / Function	Operation / Condition
IC1	Audio power amplifier	0.5W/16Ω, BTL method
IC2	Shift register	
IC3	MIC noise canceling circuit	
IC4	Option board (MAND) control switch	AND circuit MAND : "H", OUT : "H" when Q3 port is "H"
IC5	Option board (OPPTT) control switch	AND circuit OPPTT : "H", OUT : "H" when Q4 port is "H"
IC6	Option board (TCONT) control switch	AND circuit MAND : "H", OUT : "H" when Q4 port is "H"
IC7	Shift register	
IC10	Inverter	
IC101	LCD driver	
IC501	RF power amplifier	
Q5	Power supply switch control	AF AMP SW "H" : on
Q6	AF amplifier power supply switch	
Q7	Int. audio mute switch	INT. AFC "H" : INT. SP audio signal on
Q8	Audio mute switch signal off	MUTE "L" : RX audio
Q14	Noise cancelling (N/C) switch	N/C switch "H" : N/C on
Q15	Ext. audio mute switch	EXT AFC "H" : EXT. SP audio signal on
D2	AVR	AF AMP power supply
D6~9	Key pad backlight	
D11	Reverse current prevention for number key pad	
D12,13	Reverse current prevention for PF key.	
D14	Reverse current prevention for number key pad	
D15,16	Reverse current prevention for PF key.	
D17,18	Reverse current prevention for number key pad	
D19,20	Reverse current prevention for PF key.	
D101	Speed up	
D102,103	LCD backlight	
D104	LED	Red, green

DESCRIPTION OF COMPONENTS

TX-RX UNIT (X57-5400-XX) -10 : K,K4 -11 : K2 -12 : K3,K6

Ref. No.	Use / Function	Operation / Condition	Ref. No.	Use / Function	Operation / Condition
IC2	Level shift		Q301	Noise amplifier	RX on
IC3	D/A converter (adjustment)		Q302	IF amplifier	Post amplifier
IC4	DC-DC converter	Outputs \pm twice the input voltage 5M	Q303	DC switch	2nd IF W/N switch sets to on when Narrow
IC5	Phase locked loop system		Q304	DC switch	2nd IF W/N switch sets to on when Wide
IC6	Level shift		Q305	DC switch	
IC7	APC comparator		Q400	DC switch	5TC "H" : on
IC10 or L800	VCO system		Q401	DC switch	5CC "H" : on, 5TC "H" : on
IC200	Active DBM		Q402	DC switch	Regulator 5T, 5C
IC300	FM IF system	2nd mixer, Quadrature detector, AF output, Noise amplifier output, S-meter output	Q403	DC switch	MIC mute
IC301	Audio mute switch		Q404	DC switch	MIC switch
IC400	Shift register	Output expander	Q405	DC switch	5CC "H" : on
IC401	Voltage regulator	5CM	Q406	DC switch	5R
IC402	Voltage regulator	5M	Q407	Clock frequency shift	
IC403~405	Shift register	Output expander	Q408	DC switch	TX LED (Red) driver
IC406	Microprocessor	16 bit	Q409	DC switch	Busy LED (Green) driver
IC409	Voltage detector	Reset	Q410	DC switch	Lamp
IC412	EEPROM		Q411	Current driver	Lamp : Backlight
IC413	Active filter	For HSD output	Q412	DC switch	SB
IC414	Flash ROM		Q413	DC switch	BATT voltage detector
IC415	Address decode latch	NOR gate	Q414	DC switch	Power supply switch
IC600	DTMF decoder		Q415	DC switch	SB
IC601	Buffer amplifier		Q601	Mute switch	MIC line mute
IC602	Active filter	LPF for LSD input	Q602	DC switch	
IC603	D/A converter (Adjustment)		D4	Noise rejection	
IC604	Summing amplifier/ Buffer amplifier	AF/TO	D6	Current steering	
IC605	Summing amplifier	MOD : Summing amplifier	D7	TX/RX switch	
IC606	Active filter	LPF for 2-tone	D8	Temperature compensation	
IC607	Audio processor		D9	Voltage protection	
Q2	DC convert switch		D10,11	ANT switch	
Q3	RF amplifier	Buffer for RF input	D200	Overload protection	
Q4	Ripple filter	4C	D201,202	Varactor tuning	For L205
Q5	Buffer amplifier		D203,204	Varactor tuning	For L210
Q6	RF amplifier	TX drive	D300	AM detector	Noise squelch
Q7	DC switch	APC circuit power switch	D301	DC switch	Squelch speed up
Q8	RF amplifier	TX drive	D302,303	RF switch	2nd IF wide/narrow
Q9	DC switch	APC voltage control	D400	Reverse protection	
Q10	DC switch	APC off : Speed up	D401	Overload protection	
Q13	DC switch	D/A port protection	D402,403	Surge absorption	
Q200,201	RF amplifier	RX front	D404	Reverse current prevention	
			D408	Reverse current prevention	
			D409	Voltage reference	
			D601	Voltage clamp	

TK-390

PARTS LIST

* New Parts. Δ indicates safety critical components.

Parts without **Parts No.** are not supplied.

Les articles non mentionnés dans le **Parts No.** ne sont pas fournis.

Teile ohne **Parts No.** werden nicht geliefert.

L : Scandinavia

Y : PX (Far East, Hawaii)

Y : AAFES (Europe)

K : USA

T : England

X : Australia

P : Canada

E : Europe

M : Other Areas

TK-390

FINAL UNIT (X45-3590-10), CONTROL UNIT (X53-3930-XX)

Ref. No.	Address	New parts	Parts No.	Description	Destination
TK-390					
1	1A		A02-2139-63	CABINET ASSY	K,K2,K3
	1A		A02-2140-63	CABINET ASSY (DTMF)	K4,K6
2	3A	*	A10-1374-71	CHASSIS	K,K2,K4
3	3B		A10-4015-21	CHASSIS	K3,K6
4	2B		A22-2501-25	SUB PANEL ASSY	
5	2B	*	A62-0537-53	PANEL ASSY	
7	1C		B03-0594-04	DRESSING PLATE	ACCESSORY
8	1C		B09-0363-03	CAP	ACCESSORY
9	1B		B11-1183-14	ILLUMINATION GUIDE	
10	1B		B38-0786-05	LCD	
11	1A		B42-3394-14	STANDARD LABEL	
12	1A		B43-1111-14	BADGE	
13	1D		B62-0816-30	INSTRUCTION MANUAL	
14	3A	*	B72-1344-14	MODEL NAME PLATE	K,K4
14	3A		B72-1345-04	MODEL NAME PLATE	K2
14	3A	*	B72-1346-14	MODEL NAME PLATE	K3,K6
16	1D		D32-0421-24	STOPPER	ACCESSORY
18	2B	*	E23-1102-14	TERMINAL (TX/RX-GND)	
19	3A		E23-1163-04	BATT TERMINAL	
20	1B		E29-1165-05	INTER CONNECTOR (LCD)	
-	-		E30-3325-05	CLONING CABLE	
22	2A		E37-0682-05	FLAT CABLE (TX/RX-CONT)	
23	1B		E37-0684-05	LEAD WIRE WITH CONNECTOR (SP)	
24	2B		E37-0692-05	PROCESSED LEAD WIRE (TOGGLE SW)	
25	2B		E37-0722-05	ANTENNA CABLE	
26	3B		E58-0443-25	UNIVERSAL CONNECTOR	
27	2A		E72-0411-04	TERMINAL BLOCK (BATT+)	
29	2A		F10-2300-04	SHIELDING CASE	K3,K6
30	2A,3B	*	F12-0453-14	CONDUCTIVE SHEET (TX/RX-GND)	
32	2A		G01-0891-04	COIL SPRING (BATT RELEASE)	
33	2B		G11-2537-04	SHEET (SUB PANEL)	
34	2B		G11-2554-04	SHEET (KEY TOP)	
35	2B		G11-2555-04	SHEET (TOGGLE SW)	
36	1A		G11-2658-04	SHEET (PTT)	
37	2A		G13-1678-04	CUSHION (TX/RX)	
38	1C		G13-1688-04	CUSHION (CAP)	
39	2A		G13-1695-04	CUSHION (DTMF)	K4,K6
40	3A		G13-1800-04	CUSHION (BATT TERMINAL+/-)	
41	3B		G53-0822-04	PACKING (CHASSIS)	
42	1B		G53-0823-04	PACKING (SP)	
43	2A		G53-0874-03	PACKING (RING)	
44	3A		G53-1511-04	PACKING (BATT-)	
45	3A		G53-1518-04	PACKING (BATT TERMINAL)	
47	2C		H12-3018-02	PACKING FIXTURE	
48	1C		H25-0029-04	PROTECTION BAG	
49	3D		H52-1085-02	ITEM CARTON CASE	
51	2A		J19-5330-14	HOLDER (BATT REALEASE)	
52	1A		J21-8326-14	HARDWARE FIXTURE (SIDE KEY)	
53	1B		J21-8328-14	HARDWARE FIXTURE (LCD)	
54	2A		J21-8329-14	HARDWARE FIXTURE (CONT UNIT)	
55	3A		J21-8330-04	HARDWARE FIXTURE (POWER MODULE)	K,K2,K4

Ref. No.	Address	New parts	Parts No.	Description	Destination
56	2B		J21-8343-14	HARDWARE FIXTURE	
57	1C		J29-0652-35	BELT HOOK	ACCESSORY
58	1A		J82-0047-05	FPC (SIDE KEY)	
59	2B	*	J82-0049-15	FPC (VOL-ENC)	
60	3A		J82-0052-15	FPC (UNIVERSAL CONNECTOR)	
61	2B	*	J99-0346-24	ADHESIVE TAPE (TOGGLE SW)	
63	2B		K29-5172-32	KEY TOP (TOP KEY)	
64	1A		K29-5173-13	KEY TOP (SIDE KEY)	
65	1A		K29-5193-23	KEY TOP (DTMF)	K4,K6
66	2A		K29-5220-13	LEVER KNOB (BATT RELEASE)	
67	2B		K29-5282-04	KNOB ASSY (VOL)	
68	2B		K29-5283-04	KNOB ASSY (ENC)	
69	1A		K29-5441-04	KNOB ASSY (SIDE KEY)	
A	2B		N14-0578-04	CIRCULAR NUT (VOL/ENC)	
B	2B		N14-0594-04	CIRCULAR NUT (ANT CONNECTOR)	
C	3A		N30-2608-45	PAN HEAD MACHINE SCREW	
D	3B		N67-2605-46	PAN HEAD SEMS SCREW	K3,K6
E	1A,2B		N78-2030-46	PAN HEAD TAPTITE SCREW	
F	3A		N79-2035-46	PAN HEAD TAPTITE SCREW	
G	2A,2B		N83-2004-46	PAN HEAD TAPTITE SCREW	
H	2A		N83-2005-45	PAN HEAD TAPTITE SCREW	
J	2A		N89-2605-46	BANDING HEAD TAPTITE SCREW	K,K2,K4
71	1C		N99-2004-05	SCREW SET	ACCESSORY
73	2B		R31-0638-05	VARIABLE RESISTOR	
75	2B		S60-0408-15	ROTARY SWITCH	
76	2B		S72-0402-05	TOGGLE SWITCH	
78	1B		T07-0349-05	SPEAKER	
79	2A		T91-0575-05	MIC ELEMENT	
-	-		W01-0441-05	UNIVERSAL CONNECTOR KIT	
FINAL UNIT (X45-3590-10) : K3,K6					
C801			CC73GCH1H020C	CHIP C 2.0PF C	K3,K6
C802			CC73GCH1H010C	CHIP C 1.0PF C	K3,K6
C803			CC73GCH1H101J	CHIP C 100PF J	K3,K6
C804			CK73GB1C104K	CHIP C 0.10UF K	K3,K6
C805			CC73GCH1H101J	CHIP C 100PF J	K3,K6
C806			CK73GB1C104K	CHIP C 0.10UF K	K3,K6
L801			L33-0760-05	SMALL FIXED INDUCTOR	K3,K6
IC801	3B		M68732L	RF POWER MODULE	K3,K6
CONTROL UNIT (X53-3930-XX)					
-13 : K,K2 -14 : K4 -15 : K3 -16 : K6					
D6-9			B30-2171-05	LED	
D102,103			B30-2231-05	LED	
D104			B30-2019-05	LED	
C1-5			CK73GB1H471K	CHIP C 470PF K	K4,K6
C8			CK73FB1C474K	CHIP C 0.47UF K	

PARTS LIST

TX-RX UNIT (X57-5400-XX)

Ref. No.	Address	New parts	Parts No.	Description	Desti-nation	Ref. No.	Address	New parts	Parts No.	Description	Desti-nation
C34			CC73GCH1H331J	CHIP C 330PF J		C100			C92-0560-05	CHIP-TAN 10UF 6.3WV	
C36			CC73GCH1H030C	CHIP C 3.0PF C	K3,K6	C101			CK73FB1C105K	CHIP C 1.0UF K	
C36			CC73GCH1H040C	CHIP C 4.0PF C	K,K2,K4	C150			CC73GCH1H020C	CHIP C 2.0PF C	K3,K6
C37			CK73GB1H471K	CHIP C 470PF K		C150			CC73GCH1H030C	CHIP C 3.0PF C	K,K2,K4
C38			CC73GCH1H010C	CHIP C 1.0PF C		C200			CC73GCH1H030B	CHIP C 3.0PF B	K2,K3,K6
C39			CK73GB1H102K	CHIP C 1000PF K		C200			CC73GCH1H2R5B	CHIP C 2.5PF B	K,K4
C40			C92-0560-05	CHIP-TAN 10UF 6.3WV		C201			CC73GCH1H020C	CHIP C 2.0PF C	K2
C41			CK73GB1H471K	CHIP C 470PF K		C201			CC73GCH1H050C	CHIP C 5.0PF C	K3,K6
C42			CC73GCH1H060D	CHIP C 6.0PF D		C202			CC73GCH1H030C	CHIP C 3.0PF C	
C43			C92-0507-05	CHIP-TAN 4.7UF 6.3WV		C203			CK73GB1H471K	CHIP C 470PF K	
C45			CC73GCH1H040C	CHIP C 4.0PF C	K2,K3,K6	C206			CC73GCH1H040C	CHIP C 4.0PF C	K,K4
C45			CC73GCH1H060D	CHIP C 6.0PF D	K,K4	C206			CC73GCH1H050C	CHIP C 5.0PF C	K2
C46			CK73GB1H102K	CHIP C 1000PF K		C206			CC73GCH1H060D	CHIP C 6.0PF D	K3,K6
C47			CK73GB1H471K	CHIP C 470PF K		C207			CC73GCH1H101J	CHIP C 100PF J	K2,K3,K6
C48			CK73GB1H102K	CHIP C 1000PF K		C207			CK73GB1H471K	CHIP C 470PF K	K,K4
C49			CC73GCH1H080D	CHIP C 8.0PF D	K3,K6	C209			CC73GCH1H040C	CHIP C 4.0PF C	K2
C49,50			CK73GB1H471K	CHIP C 470PF K	K,K2,K4	C209			CC73GCH1H060D	CHIP C 6.0PF D	K3,K6
C50			CK73GB1H471K	CHIP C 470PF K	K3,K6	C209,210			CC73GCH1H050C	CHIP C 5.0PF C	K,K4
C51			CC73GCH1H060D	CHIP C 6.0PF D	K3,K6	C210			CC73GCH1H050C	CHIP C 5.0PF C	K2
C52			CK73GB1H102K	CHIP C 1000PF K		C210			CC73GCH1H090D	CHIP C 9.0PF D	K3,K6
C53-57			CK73GB1H471K	CHIP C 470PF K		C211			CK73GB1H102K	CHIP C 1000PF K	
C58			CC73GCH1H101J	CHIP C 100PF J		C212,213			CK73GB1H471K	CHIP C 470PF K	
C59			CC73GCH1H100D	CHIP C 10PF D	K,K2,K4	C215			CC73GCH1H050C	CHIP C 5.0PF C	K,K2,K4
C59			CC73GCH1H150J	CHIP C 15PF J	K3,K6	C215			CC73GCH1H090D	CHIP C 9.0PF D	K3,K6
C60-64			CK73GB1H471K	CHIP C 470PF K		C216			CC73GCH1H080D	CHIP C 8.0PF D	
C66,67			CK73GB1H471K	CHIP C 470PF K		C218			CC73GCH1H040C	CHIP C 4.0PF C	K,K4
C69			CC73GCH1H050C	CHIP C 5.0PF C	K,K2,K4	C218			CC73GCH1H050C	CHIP C 5.0PF C	K2,K3,K6
C69			CC73GCH1H120J	CHIP C 12PF J	K3,K6	C219			CK73GB1H471K	CHIP C 470PF K	
C70			CC73GCH1H101J	CHIP C 100PF J		C222			CC73GCH1H050C	CHIP C 5.0PF C	K,K4
C71			CK73FB1C474K	CHIP C 0.47UF K		C222			CC73GCH1H060D	CHIP C 6.0PF D	K2
C73			C92-0543-05	CHIP-TAN 3.3UF 10WV		C222			CC73GCH1H080D	CHIP C 8.0PF D	K3,K6
C76			CC73GCH1H101J	CHIP C 100PF J		C223			CC73GCH1H101J	CHIP C 100PF J	K2,K3,K6
C77			CC73GCH1H020C	CHIP C 2.0PF C	K,K2,K4	C223			CK73GB1H471K	CHIP C 470PF K	K,K4
C77			CC73GCH1H050C	CHIP C 5.0PF C	K3,K6	C225			CC73GCH1H080D	CHIP C 8.0PF D	K3,K6
C78			CK73GB1H103K	CHIP C 0.010UF K		C225,226			CC73GCH1H050C	CHIP C 5.0PF C	K,K2,K4
C79			CK73FB1C474K	CHIP C 0.47UF K		C226			CC73GCH1H090D	CHIP C 9.0PF D	K3,K6
C80			CC73GCH1H060D	CHIP C 6.0PF D	K3,K6	C227,228			CK73GB1H471K	CHIP C 470PF K	
C81,82			CK73GB1H102K	CHIP C 1000PF K		C229			CC73GCH1H050C	CHIP C 5.0PF C	K,K2,K4
C83			CC73GCH1H010C	CHIP C 1.0PF C	K,K2,K4	C229			CC73GCH1H090D	CHIP C 9.0PF D	K3,K6
C83			CC73GCH1H020C	CHIP C 2.0PF C	K3,K6	C230			CC73GCH1H030C	CHIP C 3.0PF C	K,K4
C84			CK73GB1H102K	CHIP C 1000PF K	K,K4	C231			CC73GCH1H120J	CHIP C 12PF J	K,K4
C84,85			CK73GB1H102K	CHIP C 1000PF K	K2,K3,K6	C231			CC73GCH1H270J	CHIP C 27PF J	K2
C85			CC73GCH1H150J	CHIP C 15PF J	K,K4	C231			CC73GCH1H330J	CHIP C 33PF J	K3,K6
C86			CC73GCH1H010C	CHIP C 1.0PF C		C233			CC73GCH1H050C	CHIP C 5.0PF C	K,K4
C87			CK73GB1H102K	CHIP C 1000PF K		C234			CC73GCH1H151J	CHIP C 150PF J	
C88			CC73GCH1H090D	CHIP C 9.0PF D	K,K2,K4	C236			CC73GCH1H151J	CHIP C 150PF J	
C88			CC73GCH1H150J	CHIP C 15PF J	K3,K6	C237-239			CK73GB1H471K	CHIP C 470PF K	
C89			CC73GCH1H010C	CHIP C 1.0PF C	K,K2,K4	C241,242			CK73GB1C104K	CHIP C 0.10UF K	
C89			CC73GCH1H020C	CHIP C 2.0PF C	K3,K6	C244			CC73GCH1H151J	CHIP C 150PF J	
C90			CC73GCH1H120J	CHIP C 12PF J	K3,K6	C245			CK73GB1H102K	CHIP C 1000PF K	
C90			CC73GCH1H180J	CHIP C 18PF J	K,K2,K4	C247,248			CK73GB1H471K	CHIP C 470PF K	
C91			CC73GCH1H010C	CHIP C 1.0PF C	K,K2,K4	C251			CC73GCH1H030C	CHIP C 3.0PF C	K,K2,K4
C91			CC73GCH1H030C	CHIP C 3.0PF C	K3,K6	C251			CC73GCH1H100D	CHIP C 10PF D	K3,K6
C92			CC73GCH1H010C	CHIP C 1.0PF C	K3,K6	C253			CK73GB1H102K	CHIP C 1000PF K	K2,K3,K6
C92			CC73GCH1H080D	CHIP C 8.0PF D	K,K2,K4	C255			CK73GB1H471K	CHIP C 470PF K	
C93,94			CC73GCH1H100D	CHIP C 10PF D		C300			CK73GB1H472K	CHIP C 4700PF K	
C95			CK73GB1H102K	CHIP C 1000PF K		C301,302			CC73GCH1H221J	CHIP C 220PF J	
C96			CC73GCH1H101J	CHIP C 100PF J		C303			CK73GB1C104K	CHIP C 0.10UF K	
C97			CK73GB1H102K	CHIP C 1000PF K		C304			CK73GB1H102K	CHIP C 1000PF K	
C99			CK73GB1H102K	CHIP C 1000PF K		C305			CK73GB1H103K	CHIP C 0.010UF K	

PARTS LIST

TX-RX UNIT (X57-5400-XX)

Ref. No.	Address	New parts	Parts No.	Description	Destination	Ref. No.	Address	New parts	Parts No.	Description	Destination
C306-308			CK73GB1H102K	CHIP C 1000PF K		C483			CK73GB1H102K	CHIP C 1000PF K	
C309			C92-0602-05	CHIP-TAN 1.0UF 10WV		C484			C92-0560-05	CHIP-TAN 10UF 6.3WV	
C310,311			CK73GB1C104K	CHIP C 0.10UF K		C485			CK73GB1H102K	CHIP C 1000PF K	
C312			CK73GB1C333K	CHIP C 0.033UF K		C487			CK73GB1C104K	CHIP C 0.10UF K	
C313,314			CC73GCH1H220J	CHIP C 22PF J		C488			CK73GB1H102K	CHIP C 1000PF K	K3,K6
C315			CK73GB1H102K	CHIP C 1000PF K		C600			CK73GB1C473K	CHIP C 0.047UF K	
C316			CC73GCH1H820J	CHIP C 82PF J		C601			C92-0003-05	CHIP-TAN 0.47UF 25WV	
C317			CK73GB1H102K	CHIP C 1000PF K		C602			CK73GB1C104K	CHIP C 0.10UF K	
C318			CK73GB1C104K	CHIP C 0.10UF K		C603			CK73GB1C683K	CHIP C 0.068UF K	
C319			CK73GB1H103K	CHIP C 0.010UF K		C604			CK73GB1H103K	CHIP C 0.010UF K	
C320			C92-0560-05	CHIP-TAN 10UF 6.3WV		C606			CK73GB1H222K	CHIP C 2200PF K	
C321			CK73GB1C104K	CHIP C 0.10UF K		C607			CC73GCH1H101J	CHIP C 100PF J	
C323			C92-0560-05	CHIP-TAN 10UF 6.3WV		C608			CK73GB1H103K	CHIP C 0.010UF K	
C327			CK73GB1H103K	CHIP C 0.010UF K		C609			CC73GCH1H121J	CHIP C 120PF J	
C330-332			CK73GB1H103K	CHIP C 0.010UF K		C610			CK73GB1H103K	CHIP C 0.010UF K	
C333			CK73GB1H102K	CHIP C 1000PF K		C611			CK73GB1E123K	CHIP C 0.012UF K	
C334			CK73GB1C104K	CHIP C 0.10UF K		C612			C92-0714-05	CHIP-TAN 4.7UF 6.3WV	
C335			CK73GB1H102K	CHIP C 1000PF K		C613			CK73GB1H103K	CHIP C 0.010UF K	
C336			CK73GB1A224K	CHIP C 0.22UF K		C619			CC73GCH1H471J	CHIP C 470PF J	
C337			CK73FB1C334K	CHIP C 0.33UF K		C621			CK73GB1C104K	CHIP C 0.10UF K	
C400,401			CC73GCH1H101J	CHIP C 100PF J		C623			CK73GB1E103K	CHIP C 0.010UF K	
C403-411			CC73GCH1H101J	CHIP C 100PF J		C625,626			CK73GB1C104K	CHIP C 0.10UF K	
C413			CK73GB1H471K	CHIP C 470PF K		C627			CK73GB1H122J	CHIP C 1200PF J	
C414			CK73GB1H103K	CHIP C 0.010UF K		C629,630			CK73GB1H103K	CHIP C 0.010UF K	
C415			CK73FB1C105K	CHIP C 1.0UF K		C631,632			CK73GB1C104K	CHIP C 0.10UF K	
C416,417			CK73GB1H471K	CHIP C 470PF K		C633			CK73GB1H103K	CHIP C 0.010UF K	
C419			C92-0589-05	CHIP-TAN 47UF 6.3WV		C634,635			CK73GB1H562J	CHIP C 5600PF J	
C420			C92-0702-05	ELECTRO 47UF 6.3WV		C636			CK73GB1C333K	CHIP C 0.033UF K	
C421			CK73GB1H471K	CHIP C 470PF K		C637			CK73GB1H562J	CHIP C 5600PF J	
C422			CK73FB1C105K	CHIP C 1.0UF K		C638			CK73GB1H272J	CHIP C 2700PF J	
C423,424			CK73GB1H471K	CHIP C 470PF K		C639			CC73GCH1H090D	CHIP C 9.0PF D	
C425			CK73GB1H103K	CHIP C 0.010UF K		C640,641			CK73GB1H272J	CHIP C 2700PF J	
C426			CK73GB1H471K	CHIP C 470PF K		C642			CC73HCH1H151J	CHIP C 150PF J	
C427			CK73GB1H103K	CHIP C 0.010UF K		C643			CK73GB1H122K	CHIP C 1200PF K	
C428			C92-0004-05	CHIP-TAN 1.0UF 16WV		C644			CK73HB1H102K	CHIP C 1000PF K	
C429			CK73GB1H102K	CHIP C 1000PF K		C645			CC73GCH1H090D	CHIP C 9.0PF D	
C430			CK73FB1C105K	CHIP C 1.0UF K		C646			C92-0713-05	CHIP-TAN 10UF 6.3WV	
C431			CK73GB1H471K	CHIP C 470PF K		C647			CK73HB1A104K	CHIP C 0.10UF K	
C432			CK73FB1C105K	CHIP C 1.0UF K		C648			CC73HCH1H101J	CHIP C 100PF J	
C433			C92-0698-05	ELECTRO 47UF 16WV		C649-651			CK73HB1A104K	CHIP C 0.10UF K	
C434,435			CK73GB1H471K	CHIP C 470PF K		C652			C92-0714-05	CHIP-TAN 4.7UF 6.3WV	
C436			CK73FB1C105K	CHIP C 1.0UF K		C653,654			CK73HB1E472K	CHIP C 4700PF K	
C437			CK73GB1H472K	CHIP C 4700PF K		C655			CC73HCH1H101J	CHIP C 100PF J	
C438			CK73GB1H103K	CHIP C 0.010UF K		C656			CK73FB1H563K	CHIP C 0.056UF K	
C439			CK73GB1E103K	CHIP C 0.010UF K		C657			C92-0714-05	CHIP-TAN 4.7UF 6.3WV	
C440			CK73GB1C273K	CHIP C 0.027UF K		C659			CK73GB1C104K	CHIP C 0.10UF K	
C441,442			CK73GB1H102K	CHIP C 1000PF K		C660			C92-0560-05	CHIP-TAN 10UF 6.3WV	
C443			CK73GB1H222K	CHIP C 2200PF K		C661			CK73GB1C104K	CHIP C 0.10UF K	
C444			CC73GCH1H070D	CHIP C 7.0PF D		C663			CC73HCH1H101J	CHIP C 100PF J	
C445,446			CK73GB1H222K	CHIP C 2200PF K		C664			CK73HB1A104K	CHIP C 0.10UF K	
C447,448			CC73GCH1H180J	CHIP C 18PF J		C665			CK73GB1C333K	CHIP C 0.033UF K	
C449			CK73GB1H103K	CHIP C 0.010UF K		C666			CK73GB1E153K	CHIP C 0.015UF K	
C450			C92-0713-05	CHIP-TAN 10UF 6.3WV		C668			CK73GB1H102K	CHIP C 1000PF K	
C454			CC73GCH1H101J	CHIP C 100PF J		C669			CC73GCH1H101J	CHIP C 100PF J	
C456-477			CC73GCH1H101J	CHIP C 100PF J		C676,677			CK73GB1H471K	CHIP C 470PF K	
C478			CK73GB1C104K	CHIP C 0.10UF K		C681			CK73GB1E103K	CHIP C 0.010UF K	
C479			CC73GCH1H271J	CHIP C 270PF J		CN400			E40-5563-05	FLAT CABLE CONNECTOR	
C480			CC73GCH1H221J	CHIP C 220PF J		CN401			E40-5947-05	FLAT CABLE CONNECTOR	
C481			CK73FB1C105K	CHIP C 1.0UF K		CN403			E40-5856-05	FLAT CABLE CONNECTOR	
C482			CK73GB1C104K	CHIP C 0.10UF K							

PARTS LIST

TX-RX UNIT (X57-5400-XX)

Ref. No.	Address	New parts	Parts No.	Description	Destination	Ref. No.	Address	New parts	Parts No.	Description	Destination
CN404,405			E23-0342-05	TEST TERMINAL		L300			L40-1095-34	SMALL FIXED INDUCTOR (1UH)	
F400			F53-0143-05	FUSE		L301			L40-3391-37	SMALL FIXED INDUCTOR (3.300UH)	
CD300			L79-1072-05	TUNING COIL		L400			L92-0136-05	FERRITE CHIP	
CF300,301			L72-0916-05	CERAMIC FILTER		L401			L92-0138-05	FERRITE CHIP	
CF302,303			L72-0939-05	CERAMIC FILTER		L404			L40-1001-37	SMALL FIXED INDUCTOR (10.00UH)	
L1			L92-0138-05	FERRITE CHIP		L800		*	L78-0488-05	VCO	K,K4
L3			L92-0140-05	FERRITE CHIP		L800		*	L78-0489-05	VCO	K2
L5			L40-3981-37	SMALL FIXED INDUCTOR (0.390UH)		L800		*	L78-0490-05	VCO	K3,K6
L7			L40-2275-44	SMALL FIXED INDUCTOR (22.0NH)	K,K4	L905			L92-0138-05	FERRITE CHIP	
L7			L40-2775-44	SMALL FIXED INDUCTOR (27.0NH)	K2	X1			L77-1704-05	TCXO (16.8MHZ)	
L7			L40-3375-44	SMALL FIXED INDUCTOR (33.0NH)	K3,K6	X300			L77-1741-05	CRYSTAL RESONATOR (44.395MHZ)	
L8			L40-1275-44	SMALL FIXED INDUCTOR (12.0NH)	K,K2,K4	X400		*	L77-1863-05	CRYSTAL RESONATOR (12.0MHZ)	
L8			L40-1575-44	SMALL FIXED INDUCTOR (15.0NH)	K3,K6	X600			L77-1708-05	CRYSTAL RESONATOR (3.579545MHZ)	
L9			L40-1575-44	SMALL FIXED INDUCTOR (15.0NH)	K,K2,K4	XF301			L71-0588-05	MCF (44.85MHZ)	
L9			L40-1875-44	SMALL FIXED INDUCTOR (18.0NH)	K3,K6	CP1			R90-0714-05	MULTI-COMP 10K X4	
L10,11			L92-0149-05	FERRITE CHIP		CP700-707			R90-0741-05	MULTIPLE RESISTOR	
L12			L33-0760-05	SMALL FIXED INDUCTOR		CP711-716			R90-0741-05	MULTIPLE RESISTOR	
L13			L40-1095-34	SMALL FIXED INDUCTOR (1UH)		CP718-721			R90-0741-05	MULTIPLE RESISTOR	
L14			L33-1224-05	SMALL FIXED INDUCTOR		R4			R92-1252-05	CHIP R 0 OHM	
L15,16			L33-0761-05	SMALL FIXED INDUCTOR		R5			RK73GB1J104J	CHIP R 100K J 1/16W	
L17			L40-1092-81	SMALL FIXED INDUCTOR		R6			RK73GB1J473J	CHIP R 47K J 1/16W	
L18			L40-4791-37	SMALL FIXED INDUCTOR (4.700UH)		R7			RK73GB1J104J	CHIP R 100K J 1/16W	
L19			L40-2775-44	SMALL FIXED INDUCTOR (27.0NH)		R8			RK73GB1J682J	CHIP R 6.8K J 1/16W	
L20,21			L92-0140-05	FERRITE CHIP		R9			RK73GB1J183J	CHIP R 18K J 1/16W	
L150			L33-0760-05	SMALL FIXED INDUCTOR		R11			RK73GB1J273J	CHIP R 27K J 1/16W	
L152			L40-1075-44	SMALL FIXED INDUCTOR (10.0NH)	K,K2,K4	R13			RK73GB1J104J	CHIP R 100K J 1/16W	
L152			L40-2275-44	SMALL FIXED INDUCTOR (22.0NH)	K3,K6	R14			RK73GB1J184J	CHIP R 180K J 1/16W	
L153			L40-3375-44	SMALL FIXED INDUCTOR (33.0NH)	K2	R15			RK73GB1J682J	CHIP R 6.8K J 1/16W	
L153			L40-3975-44	SMALL FIXED INDUCTOR (39.0NH)	K,K4	R16			RK73GB1J151J	CHIP R 150 J 1/16W	
L153			L40-4775-44	SMALL FIXED INDUCTOR (47.0NH)	K3,K6	R17			RK73GB1J394J	CHIP R 390K J 1/16W	
L200			L40-3975-34	SMALL FIXED INDUCTOR (39NH/8)	K2	R18			RK73GB1J102J	CHIP R 1.0K J 1/16W	
L200			L40-4775-34	SMALL FIXED INDUCTOR (47NH/8)	K,K4	R19			RK73GB1J100J	CHIP R 10 J 1/16W	
L200			L40-5675-34	SMALL FIXED INDUCTOR (56NH/8)	K3,K6	R24			RK73GB1J102J	CHIP R 1.0K J 1/16W	
L201			L40-1875-44	SMALL FIXED INDUCTOR (18.0NH)	K,K2,K4	R25			RK73GB1J224J	CHIP R 220K J 1/16W	
L201,202			L40-2775-44	SMALL FIXED INDUCTOR (27.0NH)	K3,K6	R27			RK73GB1J472J	CHIP R 4.7K J 1/16W	
L202			L40-2275-44	SMALL FIXED INDUCTOR (22.0NH)	K,K2,K4	R28			RK73GB1J223J	CHIP R 22K J 1/16W	
L203			L40-2775-44	SMALL FIXED INDUCTOR (27.0NH)	K,K2,K4	R29			RK73GB1J184J	CHIP R 180K J 1/16W	K,K2,K4
L203			L40-5675-44	SMALL FIXED INDUCTOR (56.0NH)	K3,K6	R29			RK73GB1J224J	CHIP R 220K J 1/16W	K3,K6
L204			L40-2275-44	SMALL FIXED INDUCTOR (22.0NH)	K,K2,K4	R31			RK73GB1J101J	CHIP R 100 J 1/16W	
L204			L40-2775-44	SMALL FIXED INDUCTOR (27.0NH)	K3,K6	R32-34			RK73GB1J272J	CHIP R 2.7K J 1/16W	
L205			L79-1470-05	HELICAL BLOCK		R35			RK73EB2ER39K	CHIP R 0.39 K 1/4W	
L206			L40-1875-44	SMALL FIXED INDUCTOR (18.0NH)	K,K2,K4	R37			RK73EB2ER39K	CHIP R 0.39 K 1/4W	
L206,207			L40-2775-44	SMALL FIXED INDUCTOR (27.0NH)	K3,K6	R38			RK73GB1J272J	CHIP R 2.7K J 1/16W	K,K2,K4
L207			L40-2275-44	SMALL FIXED INDUCTOR (22.0NH)	K2	R38			RK73GB1J682J	CHIP R 6.8K J 1/16W	K3,K6
L207,208			L40-2775-44	SMALL FIXED INDUCTOR (27.0NH)	K,K4	R39			RK73EB2ER39K	CHIP R 0.39 K 1/4W	
L208			L40-2775-44	SMALL FIXED INDUCTOR (27.0NH)	K2	R40			RK73GB1J123J	CHIP R 12K J 1/16W	K3,K6
L208			L40-5675-44	SMALL FIXED INDUCTOR (56.0NH)	K3,K6	R40			RK73GB1J682J	CHIP R 6.8K J 1/16W	K,K2,K4
L209			L40-2275-44	SMALL FIXED INDUCTOR (22.0NH)	K,K2,K4	R41,42			RN73GH1J154D	CHIP R 150K D 1/16W	
L209			L40-2775-44	SMALL FIXED INDUCTOR (27.0NH)	K3,K6	R43			RK73GB1J220J	CHIP R 22 J 1/16W	K,K2,K4
L210			L79-1470-05	HELICAL BLOCK		R43			RK73GB1J470J	CHIP R 47 J 1/16W	K3,K6
L212			L40-8275-44	SMALL FIXED INDUCTOR (82.0NH)		R44,45			RN73GH1J154D	CHIP R 150K D 1/16W	
L214			L40-8275-44	SMALL FIXED INDUCTOR (82.0NH)		R46			RK73GB1J152J	CHIP R 1.5K J 1/16W	K,K2,K4
L215,216			L39-1272-05	TOROIDAL COIL		R46			RK73GB1J471J	CHIP R 470 J 1/16W	K3,K6
L217			L92-0140-05	FERRITE CHIP		R47,48			RN73GH1J154D	CHIP R 150K D 1/16W	
L218			L39-1272-05	TOROIDAL COIL		R49			RK73GB1J100J	CHIP R 10 J 1/16W	K3,K6
L219			L40-8275-44	SMALL FIXED INDUCTOR (82.0NH)		R49			RK73GB1J101J	CHIP R 100 J 1/16W	K,K2,K4
L220			L40-1575-44	SMALL FIXED INDUCTOR (15.0NH)	K,K4	R50			RK73GB1J471J	CHIP R 470 J 1/16W	
L221,222			L92-0176-05	FERRITE CHIP		R51			RK73GB1J221J	CHIP R 220 J 1/16W	
						R52			RK73GB1J103J	CHIP R 10K J 1/16W	

PARTS LIST

TX-RX UNIT (X57-5400-XX)

Ref. No.	Address	New parts	Parts No.	Description	Desti-nation	Ref. No.	Address	New parts	Parts No.	Description	Desti-nation
R53			RK73GB1J270J	CHIP R 27 J 1/16W	K3,K6	R328			RK73GB1J472J	CHIP R 4.7K J 1/16W	
R53			RK73GB1J820J	CHIP R 82 J 1/16W	K,K2,K4	R329			RK73GB1J104J	CHIP R 100K J 1/16W	
R54			RK73GB1J122J	CHIP R 1.2K J 1/16W	K3,K6	R330			R92-1252-05	CHIP R 0 OHM	
R54			RK73GB1J681J	CHIP R 680 J 1/16W	K,K2,K4	R331			RK73GB1J104J	CHIP R 100K J 1/16W	
R55			RK73GB1J100J	CHIP R 10 J 1/16W		R332			RK73GB1J224J	CHIP R 220K J 1/16W	
R56			RK73GB1J473J	CHIP R 47K J 1/16W		R333			R92-1252-05	CHIP R 0 OHM	
R57			RK73GB1J104J	CHIP R 100K J 1/16W		R334			RK73GB1J100J	CHIP R 10 J 1/16W	
R58			RK73GB1J105J	CHIP R 1.0M J 1/16W		R335			RK73GB1J681J	CHIP R 680 J 1/16W	
R59			RK73GB1J104J	CHIP R 100K J 1/16W		R336			RK73GB1J224J	CHIP R 220K J 1/16W	
R60			RK73GB1J222J	CHIP R 2.2K J 1/16W	K,K2,K4	R337			RK73GB1J332J	CHIP R 3.3K J 1/16W	
R60			RK73GB1J471J	CHIP R 470 J 1/16W	K3,K6	R339			RK73GB1J473J	CHIP R 47K J 1/16W	
R61			R92-1252-05	CHIP R 0 OHM		R340			RK73GB1J104J	CHIP R 100K J 1/16W	
R63			R92-1252-05	CHIP R 0 OHM		R341			RK73GB1J333J	CHIP R 33K J 1/16W	
R65			RK73GB1J222J	CHIP R 2.2K J 1/16W		R400			RK73GB1J102J	CHIP R 1.0K J 1/16W	
R67			R92-1252-05	CHIP R 0 OHM		R401			RK73GB1J272J	CHIP R 2.7K J 1/16W	
R69-71			RK73GB1J821J	CHIP R 820 J 1/16W		R402			RK73GB1J332J	CHIP R 3.3K J 1/16W	
R73			RK73GB1J223J	CHIP R 22K J 1/16W		R403			RK73GB1J473J	CHIP R 47K J 1/16W	
R74			RK73GB1J101J	CHIP R 100 J 1/16W		R404			RK73GB1J182J	CHIP R 1.8K J 1/16W	
R75			RK73GB1J102J	CHIP R 1.0K J 1/16W		R405			RK73GB1J332J	CHIP R 3.3K J 1/16W	
R76			RK73GB1J101J	CHIP R 100 J 1/16W		R406			RK73GB1J100J	CHIP R 10 J 1/16W	
R79			RK73GB1J104J	CHIP R 100K J 1/16W		R407			RK73GB1J102J	CHIP R 1.0K J 1/16W	
R80			RK73GB1J560J	CHIP R 56 J 1/16W		R408			RK73GB1J104J	CHIP R 100K J 1/16W	
R82			R92-1252-05	CHIP R 0 OHM		R409			RK73GB1J102J	CHIP R 1.0K J 1/16W	
R201			RK73GB1J104J	CHIP R 100K J 1/16W		R410			RK73GB1J272J	CHIP R 2.7K J 1/16W	
R202			R92-1252-05	CHIP R 0 OHM		R411			RK73GB1J821J	CHIP R 820 J 1/16W	
R203			RK73GB1J331J	CHIP R 330 J 1/16W	K2	R412			RK73GB1J182J	CHIP R 1.8K J 1/16W	
R203			RK73GB1J561J	CHIP R 560 J 1/16W	K,K3,K4	R413			RK73GB1J473J	CHIP R 47K J 1/16W	
R203			RK73GB1J561J	CHIP R 560 J 1/16W	K6	R414			R92-1252-05	CHIP R 0 OHM	
R205,206			RK73GB1J104J	CHIP R 100K J 1/16W		R415			RK73GB1J471J	CHIP R 470 J 1/16W	
R208			RK73GB1J104J	CHIP R 100K J 1/16W		R416			RK73GB1J104J	CHIP R 100K J 1/16W	
R209			R92-1252-05	CHIP R 0 OHM		R418,419			RK73GB1J104J	CHIP R 100K J 1/16W	
R210			RK73GB1J102J	CHIP R 1.0K J 1/16W	K2,K3,K6	R420			RK73GB1J103J	CHIP R 10K J 1/16W	
R210			RK73GB1J222J	CHIP R 2.2K J 1/16W	K,K4	R421			RK73GB1J223J	CHIP R 22K J 1/16W	
R212,213			RK73GB1J104J	CHIP R 100K J 1/16W		R422			RK73GB1J103J	CHIP R 10K J 1/16W	
R214			R92-1252-05	CHIP R 0 OHM		R423			RK73GB1J473J	CHIP R 47K J 1/16W	
R215			RK73GB1J222J	CHIP R 2.2K J 1/16W		R424			RK73GB1J103J	CHIP R 10K J 1/16W	
R216			RK73GB1J271J	CHIP R 270 J 1/16W		R425			RK73GB1J102J	CHIP R 1.0K J 1/16W	
R217			RK73GB1J101J	CHIP R 100 J 1/16W		R426,427			RK73GB1J103J	CHIP R 10K J 1/16W	
R218,219			R92-1252-05	CHIP R 0 OHM		R428			RK73GB1J472J	CHIP R 4.7K J 1/16W	
R220			RK73GB1J473J	CHIP R 47K J 1/16W		R429			RK73GB1J103J	CHIP R 10K J 1/16W	
R221			RK73GB1J184J	CHIP R 180K J 1/16W		R430			RK73GB1J473J	CHIP R 47K J 1/16W	
R222			RK73GB1J473J	CHIP R 47K J 1/16W		R431			RK73GB1J102J	CHIP R 1.0K J 1/16W	
R223			RK73GB1J184J	CHIP R 180K J 1/16W		R432,433			RK73GB1J473J	CHIP R 47K J 1/16W	
R227			R92-1252-05	CHIP R 0 OHM	K2,K3,K6	R434			RK73GB1J103J	CHIP R 10K J 1/16W	
R300			RK73GB1J220J	CHIP R 22 J 1/16W		R435,436			RK73GB1J102J	CHIP R 1.0K J 1/16W	
R301			RK73GB1J102J	CHIP R 1.0K J 1/16W		R437			RK73GB1J473J	CHIP R 47K J 1/16W	
R303			RK73GB1J274J	CHIP R 270K J 1/16W		R438-441			RK73GB1J102J	CHIP R 1.0K J 1/16W	
R304			RK73GB1J182J	CHIP R 1.8K J 1/16W		R442			RK73GB1J152J	CHIP R 1.5K J 1/16W	
R305			RK73GB1J183J	CHIP R 18K J 1/16W		R443			RK73GB1J821J	CHIP R 820 J 1/16W	
R306			RK73GB1J271J	CHIP R 270 J 1/16W		R444			R92-0670-05	CHIP R 0 OHM	
R307			RK73GB1J223J	CHIP R 22K J 1/16W		R445			R92-1252-05	CHIP R 0 OHM	
R308			R92-1252-05	CHIP R 0 OHM		R446			RK73GB1J472J	CHIP R 4.7K J 1/16W	
R313			RK73GB1J331J	CHIP R 330 J 1/16W		R447			RK73GB1J473J	CHIP R 47K J 1/16W	
R315			RK73GB1J472J	CHIP R 4.7K J 1/16W		R448			RK73GB1J102J	CHIP R 1.0K J 1/16W	
R317,318			RK73GB1J223J	CHIP R 22K J 1/16W		R449-451			RK73GB1J473J	CHIP R 47K J 1/16W	
R319			RK73GB1J123J	CHIP R 12K J 1/16W		R452-455			RK73GB1J104J	CHIP R 100K J 1/16W	
R320			RK73GB1J392J	CHIP R 3.9K J 1/16W		R456-459			RK73GB1J473J	CHIP R 47K J 1/16W	
R321			RK73GB1J102J	CHIP R 1.0K J 1/16W		R460-462			R92-1252-05	CHIP R 0 OHM	
R323			RK73GB1J471J	CHIP R 470 J 1/16W		R464			RK73GB1J473J	CHIP R 47K J 1/16W	
R324,325			RK73GB1J223J	CHIP R 22K J 1/16W		R466			R92-1252-05	CHIP R 0 OHM	

PARTS LIST

TX-RX UNIT (X57-5400-XX)

Ref. No.	Address	New parts	Parts No.	Description	Destination	Ref. No.	Address	New parts	Parts No.	Description	Destination
R467,468			RK73GB1J473J	CHIP R 47K J 1/16W		R652			RK73HB1J473J	CHIP R 47K J 1/16W	
R469			RK73GB1J102J	CHIP R 1.0K J 1/16W		R653			RK73HB1J184J	CHIP R 180K J 1/16W	
R470-472			R92-1252-05	CHIP R 0 OHM		R654			RN73HH1J683D	CHIP R 68K D 1/16W	
R474			RK73GB1J103J	CHIP R 10K J 1/16W		R655			RK73HB1J474J	CHIP R 470K J 1/16W	
R475-477			RK73GB1J101J	CHIP R 100 J 1/16W		R656			RN73HH1J682D	CHIP R 6.8K D 1/16W	
R478			RK73GB1J471J	CHIP R 470 J 1/16W		R657			RK73GB1J101J	CHIP R 100 J 1/16W	
R479			RK73GB1J473J	CHIP R 47K J 1/16W		R658			RK73HB1J224J	CHIP R 220K J 1/16W	
R480			RK73GB1J472J	CHIP R 4.7K J 1/16W		R659			RK73HB1J103J	CHIP R 10K J 1/16W	
R481			R92-1252-05	CHIP R 0 OHM		R660			RK73HB1J223J	CHIP R 22K J 1/16W	
R482			RK73GB1J102J	CHIP R 1.0K J 1/16W		R661			RK73HB1J394J	CHIP R 390K J 1/16W	
R483			RK73GB1J473J	CHIP R 47K J 1/16W		R662			RK73HB1J470J	CHIP R 47 J 1/16W	
R484			RK73GB1J102J	CHIP R 1.0K J 1/16W		R663			RK73HB1J220J	CHIP R 22 J 1/16W	
R486			RK73GB1J473J	CHIP R 47K J 1/16W		R664			RK73GB1J333J	CHIP R 33K J 1/16W	
R487			RK73GB1J102J	CHIP R 1.0K J 1/16W		R665,666			R92-1252-05	CHIP R 0 OHM	
R488			R92-1368-05	CHIP R 0 OHM		R668			RK73GB1J334J	CHIP R 330K J 1/16W	
R489			RK73GB1J103J	CHIP R 10K J 1/16W		R669			R92-1252-05	CHIP R 0 OHM	
R490			RK73GB1J104J	CHIP R 100K J 1/16W		R670-673			RK73GB1J472J	CHIP R 4.7K J 1/16W	
R491			R92-1252-05	CHIP R 0 OHM		R674,675			RK73HB1J473J	CHIP R 47K J 1/16W	
R493			RK73GB1J100J	CHIP R 10 J 1/16W		R677			RK73GB1J333J	CHIP R 33K J 1/16W	
R494			RK73GB1J473J	CHIP R 47K J 1/16W		R679			R92-1252-05	CHIP R 0 OHM	
R495			RK73GB1J471J	CHIP R 470 J 1/16W		R680			R92-1368-05	CHIP R 0 OHM	
R496			R92-1252-05	CHIP R 0 OHM		R688			R92-1368-05	CHIP R 0 OHM	
R601			RK73GB1J153J	CHIP R 15K J 1/16W		R742			RK73GB1J272J	CHIP R 2.7K J 1/16W	
R602			RK73GB1J223J	CHIP R 22K J 1/16W		R743			RK73GB1J473J	CHIP R 47K J 1/16W	
R603			R92-1252-05	CHIP R 0 OHM		R922			RK73GB1J103J	CHIP R 10K J 1/16W	
R605,606			R92-1252-05	CHIP R 0 OHM		R923,924			R92-1368-05	CHIP R 0 OHM	
R607			RK73GB1J153J	CHIP R 15K J 1/16W		D4			MA2S077	DIODE	
R608			RK73GB1J103J	CHIP R 10K J 1/16W		D6			MA2S111	DIODE	
R609			RK73GB1J154J	CHIP R 150K J 1/16W		D7			DAN235E	DIODE	
R610			RK73GB1J563J	CHIP R 56K J 1/16W		D8			DA221	DIODE	
R611			RK73GB1J184J	CHIP R 180K J 1/16W		D9			HZU4CLL	ZENER DIODE K3,K6	
R612			RK73GB1J334J	CHIP R 330K J 1/16W		D9			MA8062	ZENER DIODE	K,K2,K4
R614			RK73GB1J184J	CHIP R 180K J 1/16W		D10			M1809	DIODE	
R615,616			RK73GB1J103J	CHIP R 10K J 1/16W		D10			XB15A709	DIODE	
R617			R92-1252-05	CHIP R 0 OHM		D11			MA77	DIODE	
R618			RK73GB1J683J	CHIP R 68K J 1/16W		D200			HSM88AS	DIODE	
R619			RK73GB1J101J	CHIP R 100 J 1/16W		D201-204			1SV273	VARIABLE CAPACITANCE DIODE	
R621			RK73GB1J103J	CHIP R 10K J 1/16W		D300			MA742	DIODE	
R622			RK73GB1J223J	CHIP R 22K J 1/16W		D301			MA2S111	DIODE	
R623			RK73GB1J334J	CHIP R 330K J 1/16W		D302,303			DAN235E	DIODE	
R624			RK73GB1J104J	CHIP R 100K J 1/16W		D400			1SR154-400	DIODE	
R626			RK73GB1J104J	CHIP R 100K J 1/16W		D401			MA2S111	DIODE	
R628			RK73GB1J334J	CHIP R 330K J 1/16W		D402,403			NNCD6.8G	ZENER DIODE	
R629			RK73GB1J223J	CHIP R 22K J 1/16W		D404			1SS301	DIODE	
R635			RK73GB1J393J	CHIP R 39K J 1/16W		D408			1SS301	DIODE	
R636,637			R92-1252-05	CHIP R 0 OHM		D409			MA2S111	DIODE	
R638			RK73GB1J472J	CHIP R 4.7K J 1/16W		D601			MA742	DIODE	
R639			RN73GH1J913D	CHIP R 91K D 1/16W		IC2			LMC7101BIM5	MOS IC	
R640			RN73GH1J683D	CHIP R 68K D 1/16W		IC3			M62354GP	MOS IC	
R641			RN73GH1J913D	CHIP R 91K D 1/16W		IC4			MAX865	MOS IC	
R642			RN73GH1J333D	CHIP R 33K D 1/16W		IC5			SA7025DK	MOS IC	
R643			RK73GB1J564J	CHIP R 560K J 1/16W		IC6			LMC7101BIM5	MOS IC	
R644			RK73GB1J474J	CHIP R 470K J 1/16W		IC7			NJM2904V	MOS IC	
R645			RN73GH1J274D	CHIP R 270K D 1/16W		IC10		*	KCH35	VCO	K2
R646			RK73GB1J472J	CHIP R 4.7K J 1/16W		IC10		*	KCH37	VCO	K3,K6
R647			R92-1252-05	CHIP R 0 OHM		IC10		*	KCH41	VCO	K,K4
R648			RN73GH1J913D	CHIP R 91K D 1/16W		IC200			GN2011(Q)	MOS IC	
R649			RN73HH1J682D	CHIP R 6.8K D 1/16W		IC300			TA31136FN	MOS IC	
R650			RK73GB1J103J	CHIP R 10K J 1/16W		IC301			TC7S66FU	MOS IC	
R651			RK73GB1J155J	CHIP R 1.5M J 1/16W							

PARTS LIST

TX-RX UNIT (X57-5400-XX)

Ref. No.	Address	New parts	Parts No.	Description	Destination	Ref. No.	Address	New parts	Parts No.	Description	Destination
IC400			BU4094BCFV	MOS IC							
IC401,402			TK11250BM	MOS IC							
IC403-405			BU4094BCFV	MOS IC							
IC406			784214GC0648EU	MPU							
IC409			PST9132NR	MOS IC							
IC412			AT2408N10SI2.5	ROM IC							
IC413			TC75W51FU	MOS IC							
IC414			AT29C020-90TI	ROM IC							
IC415			TC7S02F	MOS IC							
IC600			LC73872M	MOS IC							
IC601			TC75W51FU	MOS IC							
IC602			TA75W01FU	MOS IC							
IC603			M62364FP	MOS IC							
IC604-606			TC75W51FU	MOS IC							
IC607			TC35453F	MOS IC							
Q2			2SJ144(GR)	FET							
Q3			2SC5066(O)	TRANSISTOR							
Q4			2SC4617(S)	TRANSISTOR							
Q5			2SC5108(Y)	TRANSISTOR							
Q6			2SC5110(O)	TRANSISTOR							
Q7			DTC114EE	DIGITAL TRANSISTOR							
Q8			2SC4988	TRANSISTOR							
Q9			DTA144EE	DIGITAL TRANSISTOR							
Q10			DTC144EE	DIGITAL TRANSISTOR							
Q13			2SK1824	FET							
Q200,201		*	3SK293	FET							
Q301			2SC4617(S)	TRANSISTOR							
Q302			2SK1215(E)	FET							
Q303			DTA144EE	DIGITAL TRANSISTOR							
Q304			DTC144EE	DIGITAL TRANSISTOR							
Q305			UMC4	TRANSISTOR							
Q400			UMG3N	TRANSISTOR							
Q401			UPA572T	FET							
Q402			FP210	TRANSISTOR							
Q403			2SJ243	FET							
Q404			DTC144EE	DIGITAL TRANSISTOR							
Q405			UMG3N	TRANSISTOR							
Q406			DTA123JE	DIGITAL TRANSISTOR							
Q407			2SC4215(Y)	TRANSISTOR							
Q408-410			2SC4617(S)	TRANSISTOR							
Q411			2SB1132(Q,R)	TRANSISTOR							
Q412			2SK1824	FET							
Q413			HN1L02FU	FET							
Q414			2SK1824	FET							
Q415			2SJ517	FET							
Q601,602			2SK1824	FET							
TH301			157-104-65001	THERMISTOR							

EXPLODED VIEW

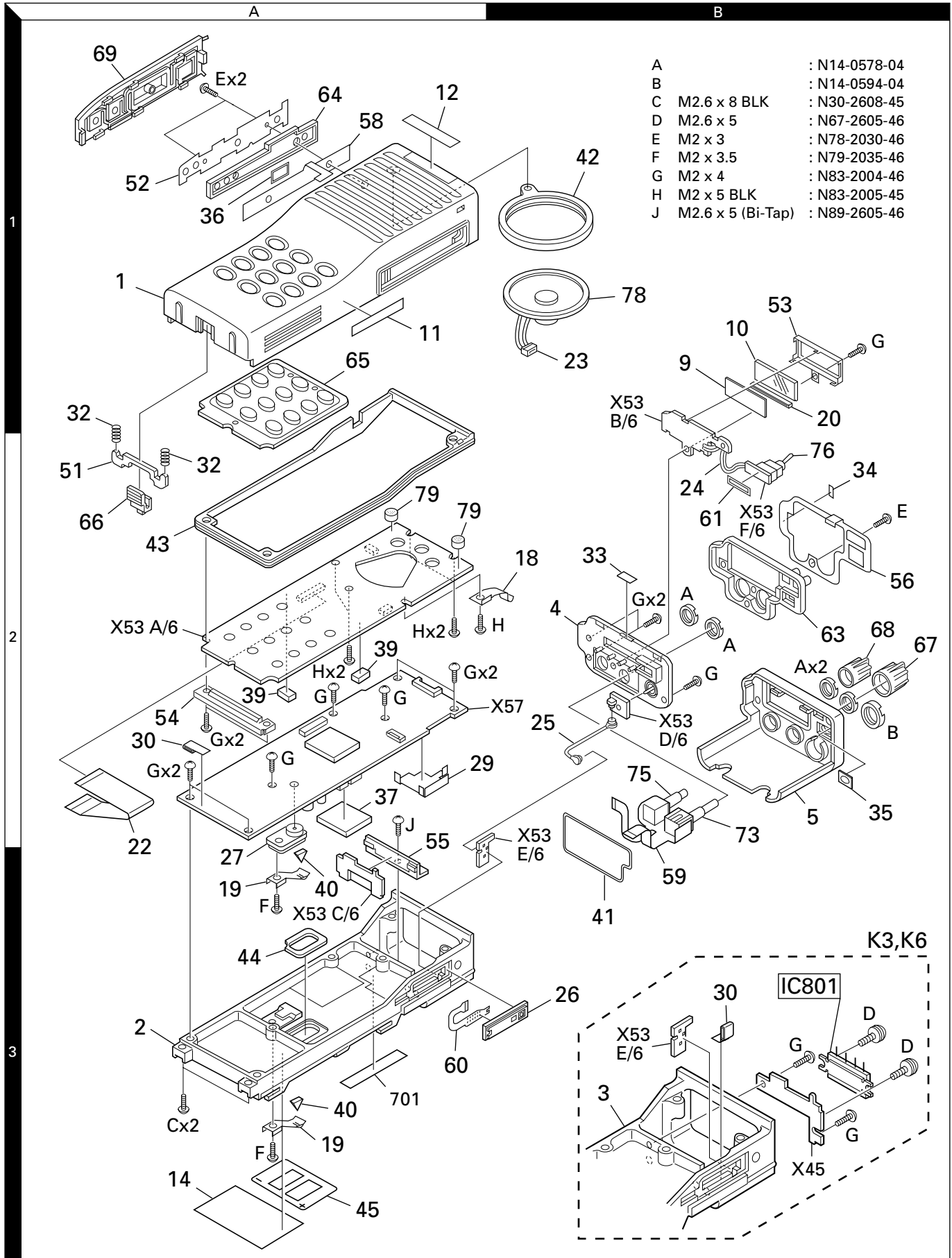

PACKING

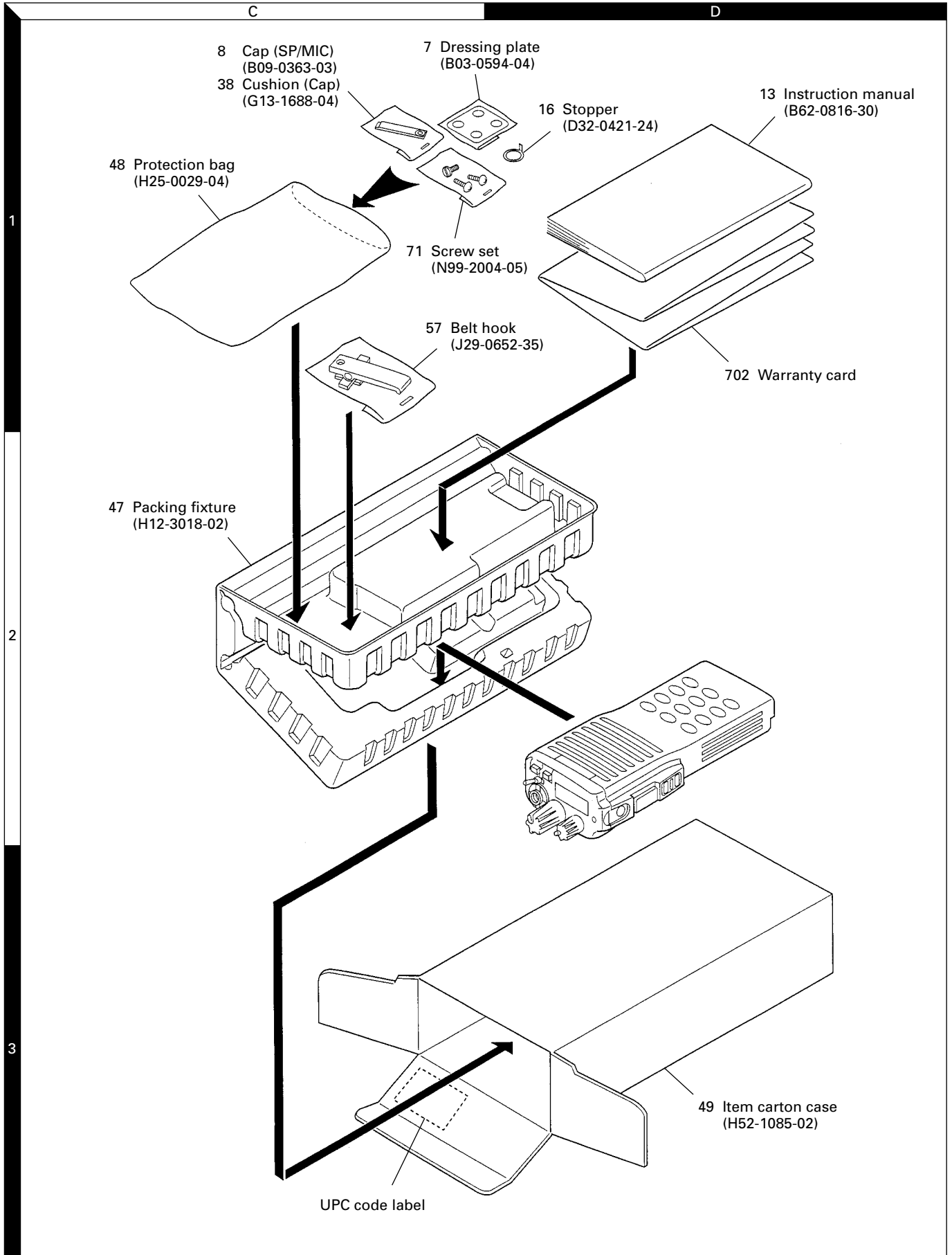

Parts with the exploded numbers larger than 700 are not supplied.

DISASSEMBLY FOR REPAIR

Disassembly of Front Case and Chassis

1. Remove the 2 screws (1) and a cap fixed screw (2).
2. Press the chassis bottom upwards and remove the clips (3) at the top. The front case is still connected to the chassis by the FPC at this time so be gentle when lifting upwards, otherwise unwanted stress is applied on the FPC.
3. The front case and chassis can only be opened to the side when connected by the FPC (4).

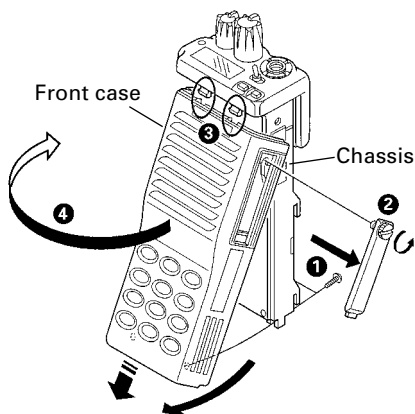

Remove the Side Key Assy

1. The side key assy is clips form a slide-hook structure. Lift up gently and take from the side (12).

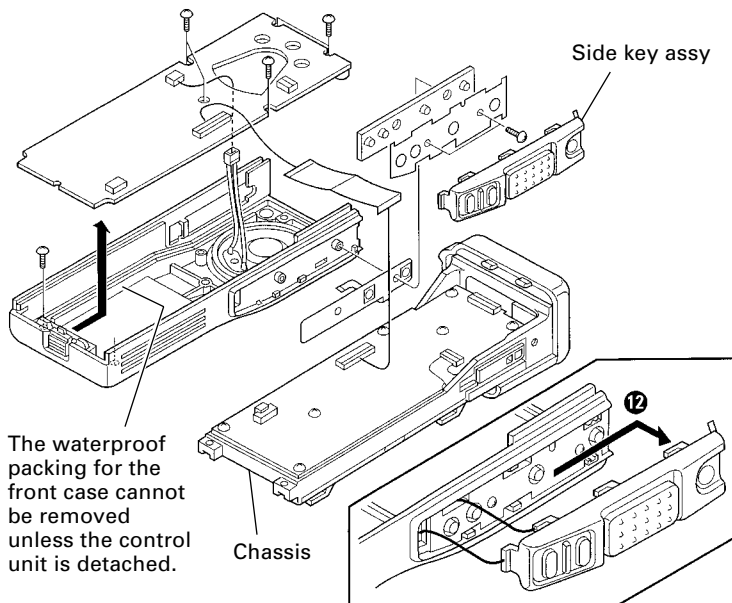

Remove the TX-RX Unit from the Chassis

1. The TX-RX unit cannot be removed simply by removing the seven screws (5).
2. A total of 9 solder connections, 6 on the RF power module (6) and 3 on the antenna daughter board (7) must be disconnected.

Remove the Universal Connector

1. The universal connector (8) is fastened to the chassis with double-side tape.
2. First unsolder the connection on the antenna daughter board (9).
3. Press firmly with a tool such as a screwdriver and so that it can peel (10).

Note : You must replace both parts together when replacing the universal connector or the FPC (11).

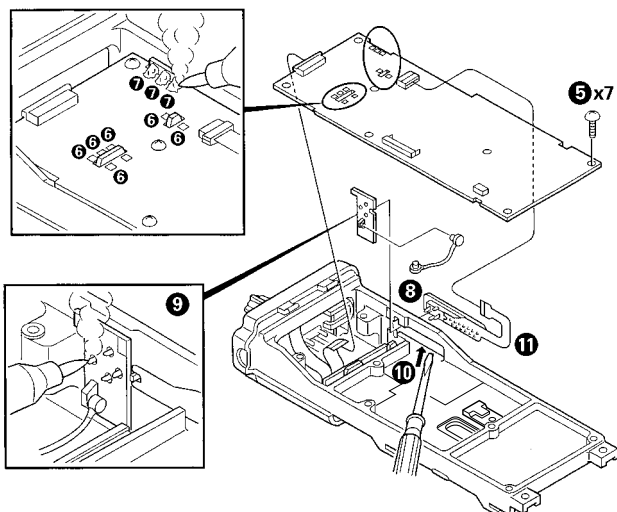

Disassembly of the Panel Assy

1. The LCD assy and toggle switch are joined by wire (13). Use caution not to break this wire during handling.

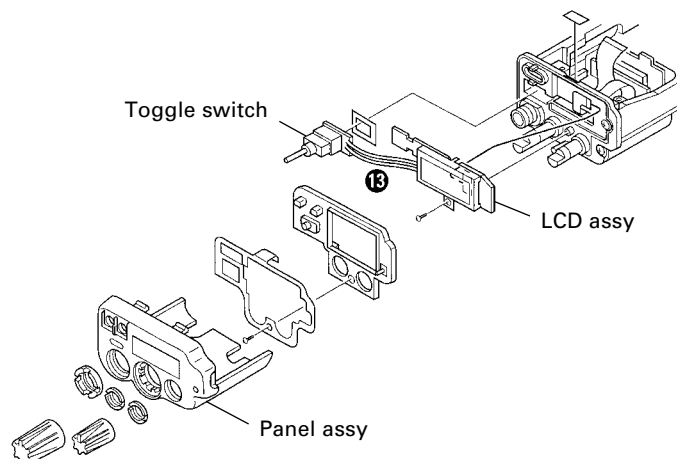

ADJUSTMENT

Test Equipment Required for Alignment

No.	Test Equipment	Major Specifications	
1	Standard Signal Generator (SSG)	Frequency Range Modulation Output	Maximum 600MHz or more. Frequency modulation and external modulation. -133dBm/0.05 μ V to 7dBm/501mV
2	Power Meter	Input Impedance Operation Frequency Measurement Range	50 Ω . Up to 600MHz. Full scale of 10W or so.
3	Deviation Meter	Frequency Range	400 to 560MHz.
4	Digital Volt Meter (DVM)	Measuring Range Accuracy	FS=18V or so. High input impedance for minimum circuit loading.
5	Oscilloscope		DC through 30MHz.
6	High Sensitivity Frequency Counter	Frequency Range Frequency Stability	Up to 1GHz or so. 0.2ppm or less.
7	Ammeter		5A.
8	AF Volt Meter (AF VTVM)	Frequency Range Voltage Range	50Hz to 1MHz. 1mV to 10V.
9	Audio Generator (AG)	Frequency Range Output	100Hz to 100kHz or more. 0 to 1V.
10	Distortion Meter	Capability Input Level	3% or less at 1kHz. 50mV to 10Vrms.
11	16 Ω Dummy Load		Approx. 16 Ω , 5W.
12	Regulated Power Supply		5V to 10V, approx. 5A Useful if ammeter equipped.
13	Spectrum Analyzer	Measuring Range	DC to 1GHz or more.
14	Tracking Generator	Center Frequency Frequency Deviation Output Voltage	50kHz to 600MHz. \pm 35MHz. 100mV or more.

■ The following parts are required for adjustment

1. Antenna connector adapter

The antenna connector of this radio uses an SMA terminal.

Use an antenna connector adapter [SMA(f) – BNC(f) or SMA(f) – N(f)] for adjustment. (The adapter is not provided as an option, so buy a commercially-available one.)

Note

When the antenna connector adapter touches the knob, draw out the knob to mount the connector.

2. Universal connector

Use the interface cable (KPG-36) for PC tuning or the lead wire with plug (E30-3287-08) and screw (N08-0535-08) for panel tuning. Connect the plug to the universal connector of the radio and tighten the screw.

The lead wire with plug (E30-3287-08) and screw (N08-0535-08) terminals are as follows. Numbers are universal connector terminal numbers.

Caution

- When connecting the plug to the universal connector of the radio, a short circuit may occur. To prevent this, be sure to turn the radio POWER switch off.
- Since the RX AF output is a BTL output, there is a DC component. Isolate this with a capacitor or transformer as shown in the figure.
- Do not connect an instrument between red or black and GND.

• Universal connector

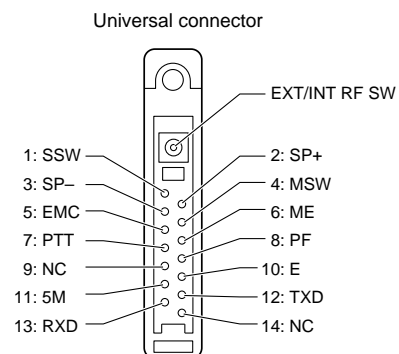

ADJUSTMENT

• Panel tuning

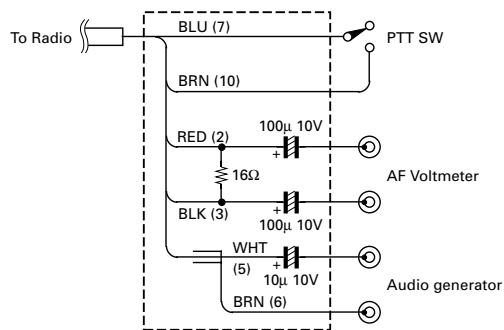
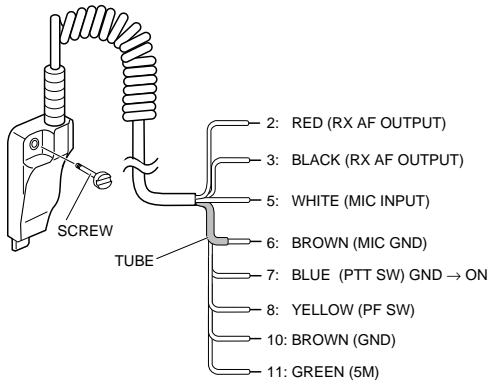

• PC tuning

Connect the wires to the PCB in the connector case of interface cable.

For output the wires out of the connector case, need to process the connector case.

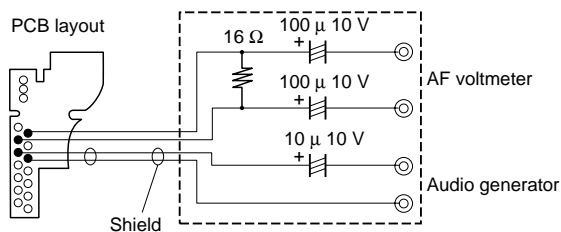
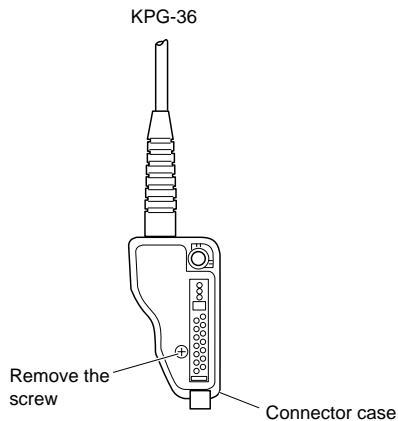

Repair Jig (Chassis)

Use jig (part No.: A10-1399-03) for repairing the TK-390. Place the TX-RX unit on the jig and fit it with 7 screws.

Note : Supply power from an external power supply (Battery terminal : +, jig (chassis) : -)

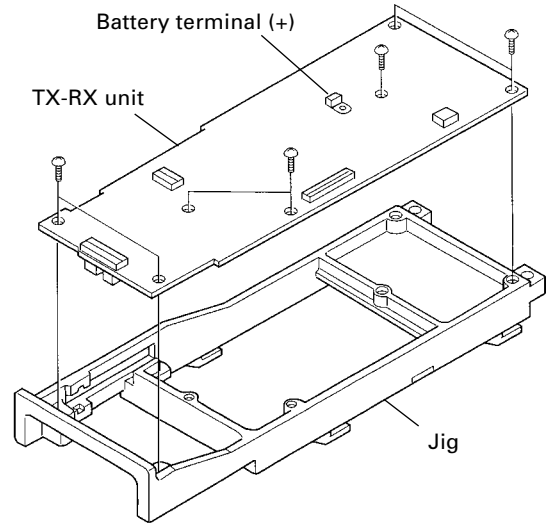

How to Remove the Flat Cable

1. Gently draw out both sides of the connector lever uniformly in the direction of the arrow with tweezers. (CN101, CN400)

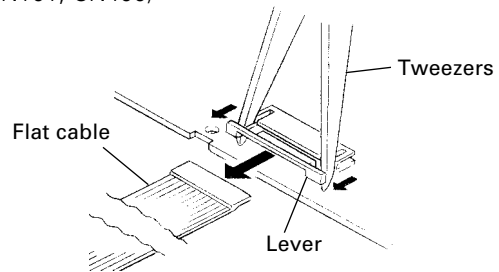

2. Gently rise up the connector lever in the direction of the arrow with a fine regular screwdriver or tweezers. (CN1, CN3, CN401, CN403)

Note : Gently push both sides of the connector lever, when put in the flat cable.

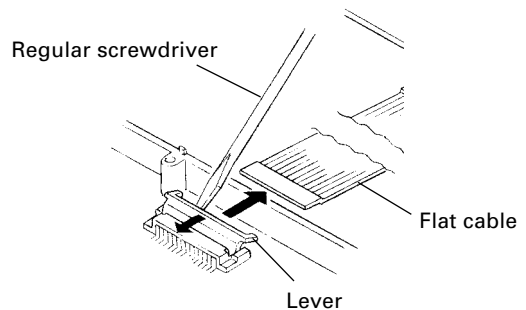

ADJUSTMENT

Panel Test Mode

This mode is used for making transceiver connection tests and clearing the memory.

To set Panel test mode, turn on the power with [Side 2] and [PTT] are still held down and then first release [PTT]. This mode cannot be set when disabled with the FPU.

In Panel test mode, when channel or signalling is selected, the signalling that was most recently used is displayed.

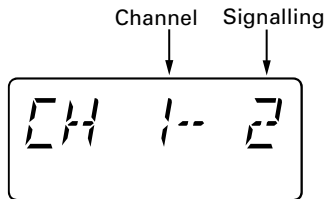

Key operations in Panel test mode are as follows.

- [Selector switch] : Use to select the test channel.
- [PTT] : For transmit.
- [Top 1] : For down signalling.
- [Top 2] : For up signalling.
- [Side 1] : For setting Panel tuning mode.
- [Side 2] : For switching power between Hi/Low.
Enter the LCD all lamp mode if held down for 2 seconds.
- [Orange] : For monitoring.
- [Toggle] : For switching between Wide/Narrow.

Frequency (MHz)

CH	RX	TX
1	470.1000 (Center)	470.0000 (Center)
2	450.1000 (Low)	450.0000 (Low)
3	489.9000 (Hi)	489.9750 (Hi)
4	470.0000	470.0000
5	470.2000	470.2000
6	470.4000	470.4000

Signalling

No.	Encode tone	Decode tone
1	None	None
2	QT 67.0Hz	QT 67.0Hz
3	QT 250.3Hz	QT 25.03Hz
4	DQT 023N	DQT 023N
5	None	2 tone 321.7/928.1Hz
6	DTMF (9)	DTMF (159)
7	MSK PN pattern	None
8	100Hz square wave	None
9	Single tone 1633Hz	None

LCD all lamp mode

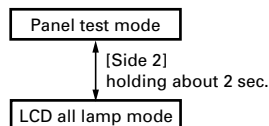

Clear function

Pressing [PTT] while holding down [Orange] in Panel test mode, triggers the clear function which clears all transceiver data settings.

Panel tuning mode

Press [Side 1] in Panel test mode to set Panel tuning mode.

Note : Different sample displays are shown.

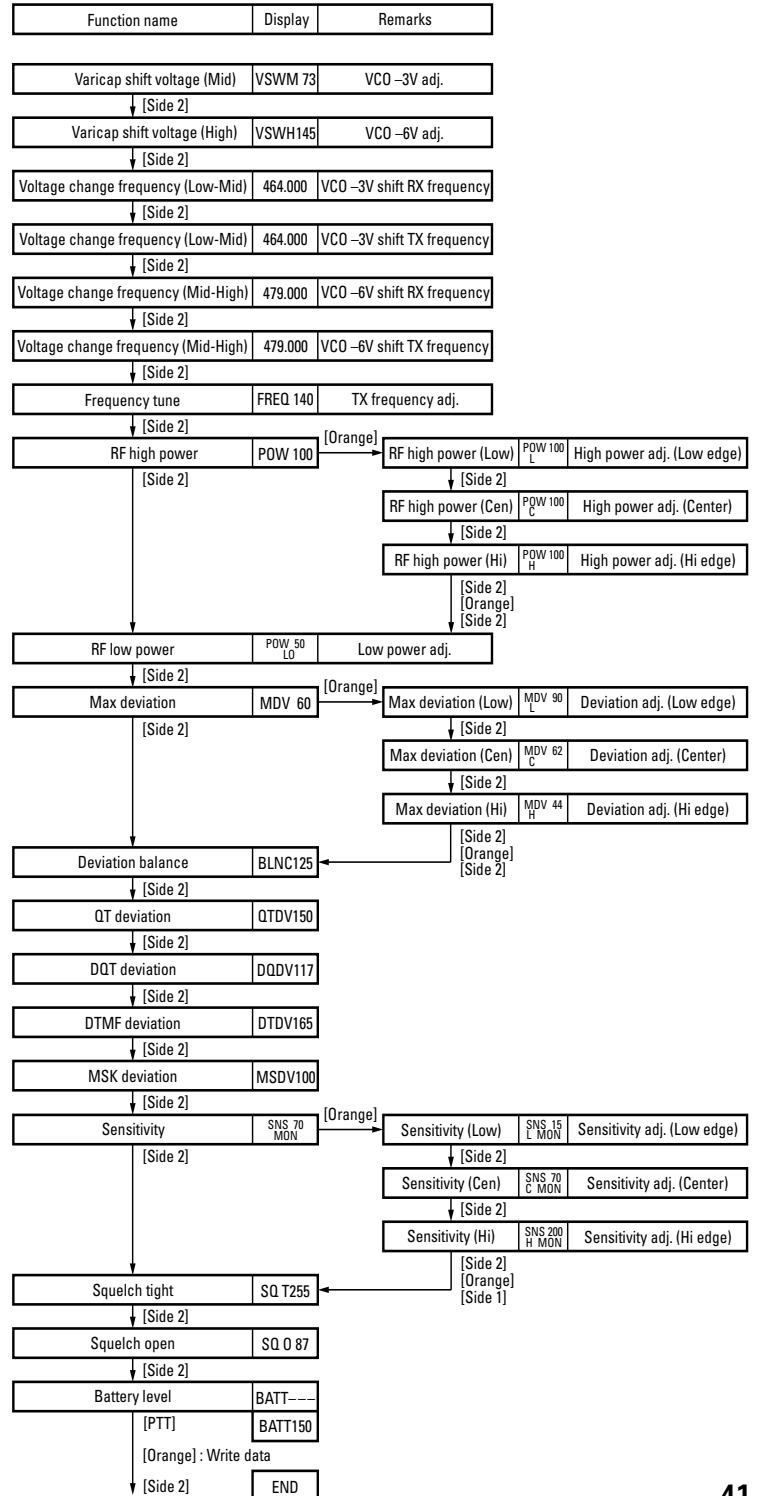

ADJUSTMENT

Common Section

Item	Condition	Measurement			Adjustment			Specifications/Remarks
		Test-equipment	Unit	Terminal	Unit	Parts	Method	
1. Varicap shift voltage Mid	1) Set panel tuning mode Push Side2 to select VSWM ***	DC VTVM	TX-RX	TP2	Panel	Top1/ Top2	-3V	±0.1V
High	2) Push Side2 to select VSWH ***						-6V	±0.1V
2. Voltage change frequency Low-Mid RX	1) Set panel tuning mode Push Side2 to select ***.*** r1			TP1			4.15V	±0.05V
TX	2) Push Side2 to select ***.*** t1						4.15V	±0.05V
Mid-Hi RX	3) Push Side2 to select ***.*** r2						4.15V	±0.05V
TX	4) Push Side2 to select ***.*** t2						4.15V	±0.05V

Caution : When adjusting transmit power and sensitivity, connect the cable to the SMA antenna connector on the top panel. At this time, use the antenna-less type jig connector (E30-3287-08) in the universal connector.

Transmitter Section

Item	Condition	Measurement			Adjustment			Specifications/Remarks
		Test-equipment	Unit	Terminal	Unit	Parts	Method	
1. Frequency adjustment	1) Set panel test mode CH No. : 1 Signalling No. : 1 Select FRQ *** in panel tuning mode PTT : ON	Power meter f. counter	Panel	ANT	Panel	Top1/ Top2	470.000MHz	±50Hz
2. Maximum power check	1) Set panel test mode CH No. : 3 Signalling No. : 1 BATT terminal voltage : 7.5V Select POW 255 in panel tuning mode PTT : ON	Power meter Ammeter	Panel	ANT			Check	4.0W or more
3. TX high power adjustment	1) Set panel test mode CH No. : 3 Signalling No. : 1 Select POW *** in tuning mode Push Orange to 3 point adjustment mode Select POW *** L PTT : ON				Panel	Top1/ Top2	4.20W	±0.1W 2.3A or less
	2) Push Side2 to select POW *** M PTT : ON							
	3) Push Side2 to select POW *** H PTT : ON							

ADJUSTMENT

Item	Condition	Measurement			Adjustment			Specifications/Remarks
		Test-equipment	Unit	Terminal	Unit	Parts	Method	
4. TX high power check	1) Set panel test mode CH No. : 1 Signalling No. : 1 PTT : ON	Power meter	Panel	ANT			Check	3.7W~5.2W 2.3A or less
	2) CH No. : 2 Signalling No. : 1 PTT : ON	Ammeter						
	3) CH No. : 3 Signalling No. : 1 PTT : ON							
5. TX low power adjustment	1) Set panel test mode CH No. : 3 Signalling No. : 1 Select POW *** LO in panel tuning mode PTT : ON				Panel	Top1/ Top2	1.0W	±0.1W 1.2A or less
6. TX low power check	1) Set panel test mode CH No. : 1 Signalling No. : 1 Set low power (Push Side2) PTT : ON						Check	0.5W~1.5W 1.2A or less
	2) CH No. : 2 Signalling No. : 1 Set low power (Push Side2) PTT : ON							
	3) CH No. : 3 Signalling No. : 1 Set low power (Push Side2) PTT : ON							
7. DQT balance adjustment	1) Set panel test mode CH No. : 3 Signalling No. : 1 Select BLNC *** in panel tuning mode Deviation meter filter setting LPF : 3kHz HPF : OFF PTT : ON	Power meter Deviation meter Oscilloscope	Panel	ANT	Panel	Top1/ Top2	Make the demodulation waves into square waves.	
		AG AF VTVM	Side	Universal				

ADJUSTMENT

Item	Condition	Measurement			Adjustment			Specifications/Remarks
		Test-equipment	Unit	Terminal	Unit	Parts	Method	
8. Maximum deviation adjustment (Wide)	1) Set panel test mode CH No. : 3 Signalling No. : 1 Select MDV *** in panel tuning mode Push Orange to 3 point adjustment mode Select MDV *** L AG : 1kHz/150mV Deviation meter filter setting LPF : 15kHz HPF : OFF PTT : ON	Power meter Deviation meter Oscilloscope	Panel	ANT	Panel	Top1/ Top2	3.95kHz (According to the larger +, -)	±50Hz
	2) Push Side2 to select MDV *** M PTT : ON	AG	Side	Universal				
	3) Push Side2 to select MDV *** H PTT : ON	AF VTVM						
9. Maximum deviation adjustment (narrow)	1) Set panel test mode CH No. : 3 Signalling No. : 1 Select MDV *** in panel tuning mode Turn the toggle SW to the right (narrow). Push Orange to 3 point adjustment mode Select MDV *** N L AG : 1kHz/150mV Deviation meter filter setting LPF : 15kHz HPF : OFF PTT : ON						1.90kHz (According to the larger +, -)	±50Hz
	2) Push Side2 to select MDV *** N M PTT : ON							
	3) Push Side2 to select MDV *** N H PTT : ON							
10. MIC sensitivity check	1) Set panel test mode CH No. : 3 Signalling No. : 1 AG : 1kHz/15mV Deviation meter filter setting LPF : 15kHz HPF : OFF PTT : ON						Check	1.8kHz~3.6kHz
	2) Turn the toggle SW to the right (narrow) PTT : ON							0.9kHz~1.8kHz

ADJUSTMENT

Item	Condition	Measurement			Adjustment			Specifications/Remarks
		Test-equipment	Unit	Terminal	Unit	Parts	Method	
11. QT deviation adjustment (wide)	1) Set panel tuning mode CH No. : 3 Signalling No. : 1 MIC input : OFF Select QTDV *** in panel tuning mode Deviation meter filter setting LPF : 3kHz HPF : 50Hz De-emphasis : 750μs PTT : ON	Power meter Deviation meter Oscilloscope AG AF VTVM	Panel Side	ANT Universal	Panel	Top1/ Top2	0.75kHz	±0.05kHz
12. QT deviation adjustment (narrow)	1) Set panel tuning mode CH No. : 3 Signalling No. : 1 MIC input : OFF Select QTDV *** in panel tuning mode Turn the toggle SW to the right (narrow) Deviation meter filter setting LPF : 3kHz HPF : 50Hz De-emphasis : 750μs PTT : ON						0.375kHz	±0.05kHz
13. DQT deviation adjustment (wide)	1) Set panel test mode CH No. : 3 Signalling No. : 1 Select DQDV *** in panel tuning mode Deviation meter filter setting LPF : 3kHz HPF : OFF PTT : ON						0.75kHz	±0.05kHz
14. DQT deviation adjustment (narrow)	1) Set panel tuning mode CH No. : 3 Signalling No. : 1 Select DQDV *** in panel tuning mode Turn the toggle SW to the right (narrow) Deviation meter filter setting LPF : 3kHz HPF : OFF PTT : ON						0.375kHz	±0.05kHz
15. DTMF deviation adjustment (wide)	1) Set panel test mode CH No. : 3 Signalling No. : 1 Select DTDV *** in tuning mode Deviation meter filter setting LPF : 15kHz HPF : OFF PTT : ON						3.0kHz	±50Hz

ADJUSTMENT

Item	Condition	Measurement			Adjustment			Specifications/Remarks
		Test-equipment	Unit	Terminal	Unit	Parts	Method	
16. DTMF deviation adjustment (narrow)	1) Set panel tuning mode CH No. : 3 Signalling No. : 1 Select DTDV *** in panel tuning mode Turn the toggle SW to the right (narrow) Deviation meter filter setting LPF : 15kHz HPF : OFF PTT : ON	Power meter Deviation meter Oscilloscope AG AF VTVM	Panel Side	ANT Universal	Panel	Top1/ Top2	1.5kHz	±50Hz
17. MSK deviation adjustment (wide)	1) Set panel test mode CH No. : 3 Signalling No. : 1 Select MSDV *** in panel tuning mode Deviation meter filter setting LPF : 15kHz HPF : OFF PTT : ON						3.00kHz	±50Hz
18. MSK deviation adjustment (narrow)	1) Set panel tuning mode CH No. : 3 Signalling No. : 1 Select MSDV *** in panel tuning mode Turn the toggle SW to the right (narrow) Deviation meter filter setting LPF : 15kHz HPF : OFF PTT : ON						1.50kHz	±50Hz
19. Transmission S/N check (wide)	1) Set panel test mode CH No. : 3 Signalling No. : 1 Deviation meter filter setting LPF : 300Hz HPF : 3kHz De-emphasis : 750µs PTT : ON						Check	42dB or more
20. Transmission S/N check (narrow)	1) Set panel test mode CH No. : 3 Signalling No. : 1 Turn the toggle SW to the right (narrow) Deviation meter filter setting LPF : 300Hz HPF : 3kHz De-emphasis : 750µs PTT : ON							37dB or more
21. BATT detection writing	1) Set panel test mode CH No. : 3 Signalling No. : 1 Select BATT *** in panel tuning mode PTT : ON	Power meter DC VTVM	Panel Bottom	ANT BATT terminal	Side	Orange	Write the voltage level	6.2V

ADJUSTMENT

Item	Condition	Measurement			Adjustment			Specifications/Remarks
		Test-equipment	Unit	Terminal	Unit	Parts	Method	
22. BATT detection check	1) Set panel test mode CH No. : 3 Signalling No. : 1 BATT terminal voltage : 5.3V PTT : ON	Power meter	Panel	ANT			Check	Cannot transmit LED (TX) blinks
	2) BATT terminal voltage : 6.5V PTT : ON	DC VTVM	Bottom	BATT terminal				Transmit

Receiver Section

Item	Condition	Measurement			Adjustment			Specifications/Remarks
		Test-equipment	Unit	Terminal	Unit	Parts	Method	
1. AF level check	1) Set panel test mode CH No. : 3 Signalling No. : 1 SSG freq. : Each freq. output : -53dBm/501 μ V MOD. : 1kHz DEV. : 3kHz	SST	Panel	ANT			Check	0.63V \pm 0.3V 3% or less
	2) Turn the toggle SW to the right (narrow) SSG freq. : Each freq. output : -53dBm/501 μ V MOD. : 1kHz DEV. : 1.5kHz	AF VTVM Oscilloscope Distortion meter Audio analyzer	Side	Universal				0.63V \pm 0.3V 5% or less
2. Hum and noise ratio check	1) Set panel test mode CH No. : 3 Signalling No. : 1 SSG output : -53dBm/501 μ V							42dB or more
	2) Turn the toggle SW to the right (narrow) SSG output : -53dBm/501 μ V							37dBm
3. BPF coil Use this adjustment procedure after replacing any of the BPF coils	1) Set panel test mode CH No. : 2 Connect the spectrum analyzer to TP3. Signalling No. : 1 Push Orange to 3 point adjustment mode Select SNS 25 L	Tracking generator Spectrum analyzer	Panel TX-RX	ANT TP3	TX-RX	L205 L210	Adjust the BPF coil so that the waveform is peaked. The frequency with the peak waveform does not have to be the center frequency. After finished peaking the waveform, perform a 3 point adjustment and set for maximum sensitivity.	

ADJUSTMENT

Item	Condition	Measurement			Adjustment			Specifications/Remarks
		Test-equipment	Unit	Terminal	Unit	Parts	Method	
4. Sensitivity adjustment and check (wide)	1) Set panel test mode CH No. : 3 Signalling No. : 1 Select SNS *** in panel tuning mode Push Orange to 3 point adjustment mode Select SNS *** L SSG freq. : Low output : -116dBm/0.35μV	SSG AF VTVM Oscilloscope Distortion meter Audio analyzer	Panel Side	ANT Universal	Panel	Top1/ Top2	Adjust for maximum SINAD	12dB SINAD or more
	2) Push Side2 to select SNS *** M SSG freq. : Center							
	3) Push Side2 to select SNS *** H SSG freq. : Hi							
5. Sensitivity check (narrow)	1) Set panel test mode CH No. : 1 Signalling No. : 1 SSG output : -116dBm/0.35μV MOD. : 1kHz DEV. : 1.5kHz Turn the toggle SW to the right (narrow)					Check	12dB SINAD or more	
	2) Set panel test mode CH No. : 3 Signalling No. : 1 Turn the toggle SW to the right (narrow)							
	3) Set panel test mode CH No. : 5 Signalling No. : 1 Turn the toggle SW to the right (narrow)							
6. Tight squelch adjustment (wide)	1) Set panel test mode CH No. : 3 Signalling No. : 1 Select SQ T*** in panel tuning mode SSG output : 6dB above to 12dB SINAD level.				Panel	Top1/ Top2	Adjust to point of opening squelch	
7. Tight squelch adjustment (narrow)	1) Set panel test mode CH No. : 3 Signalling No. : 1 Select SQ T*** in panel tuning mode Turn the toggle SW to the right (narrow) SSG output : 6dB above to 12dB SINAD level.							
8. Squelch adjustment (wide)	1) Set panel test mode CH No. : 3 Signalling No. : 1 Select SQ O*** in panel tuning mode SSG output : 3dB below to 12dB SINAD level							

ADJUSTMENT

Item	Condition	Measurement			Adjustment			Specifications/Remarks
		Test-equipment	Unit	Terminal	Unit	Parts	Method	
9. Squelch adjustment (narrow)	1) Set panel test mode CH No. : 3 Signalling No. : 1 Select SQ O * * * in panel tuning mode Turn the toggle SW to the right (narrow) SSG output : 3dB below to 12dB SINAD level	SSG	Panel	ANT	Panel	Top1/ Top2	Adjust to point of opening squelch	
10. Squelch check (wide)	1) Set panel test mode CH No. : 3 Signalling No. : 1 SSG output : -118dBm/0.28μV						Check	Squelch must be opened
	2) SSG output : -127dBm/0.1μV							Squelch must be closed
11. Squelch check (narrow)	1) Set panel test mode CH No. : 3 Signalling No. : 1 Turn the toggle SW to the right (narrow) SSG output : -118dBm						Check	Squelch must be opened
	2) SSG output : -127dBm							Squelch must be closed

Adjustment Point

■ Component side

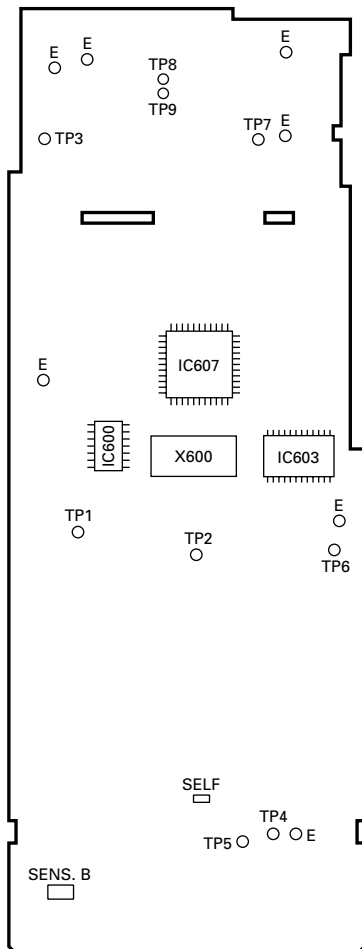

■ Foil side

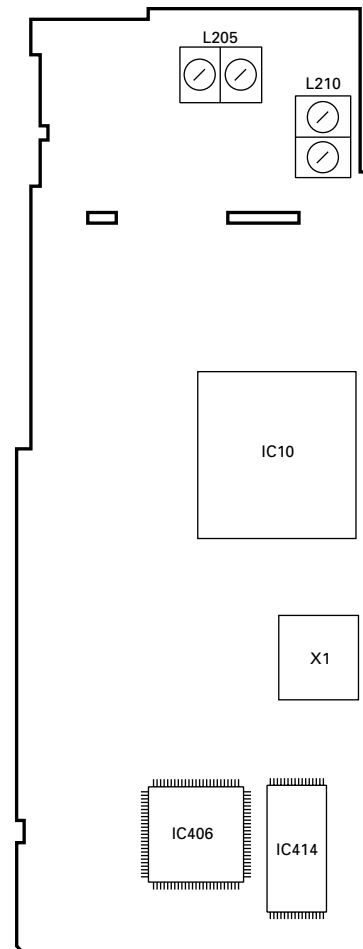

TK-390 PC BOARD VIEW

FINAL UNIT (X45-3590-10) Component side view : K3,K6

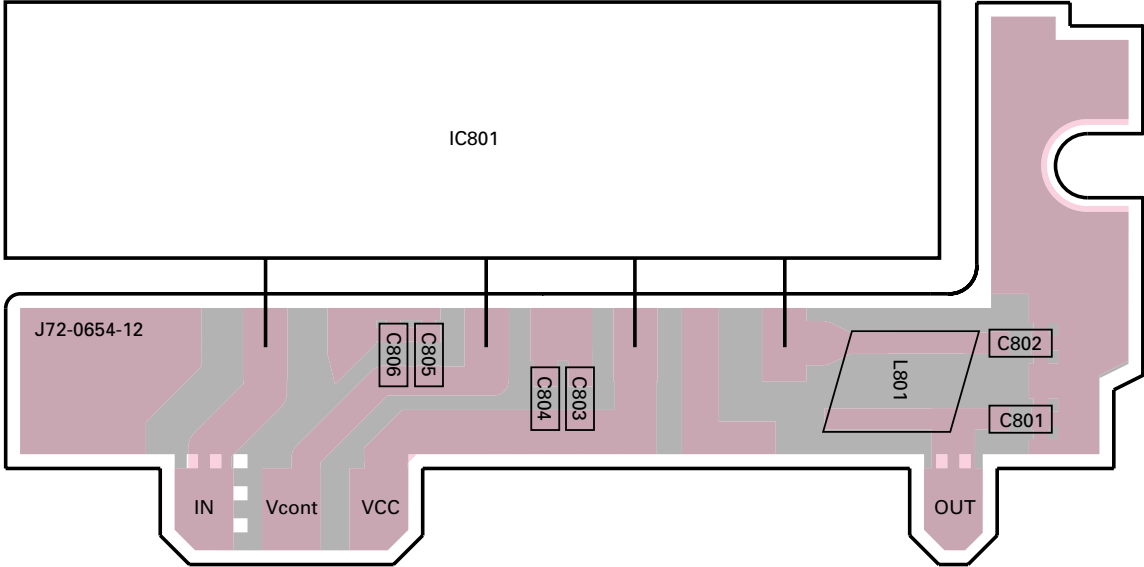

1

2

3

4

5

6

7

TK-390 PC BOARD VIEWS

CONTROL UNIT (X53-3930-XX) -13 : K,K2 -14 : K4 -15 : K3 -16 : K6 Component side view

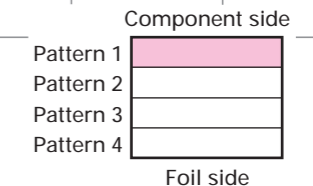
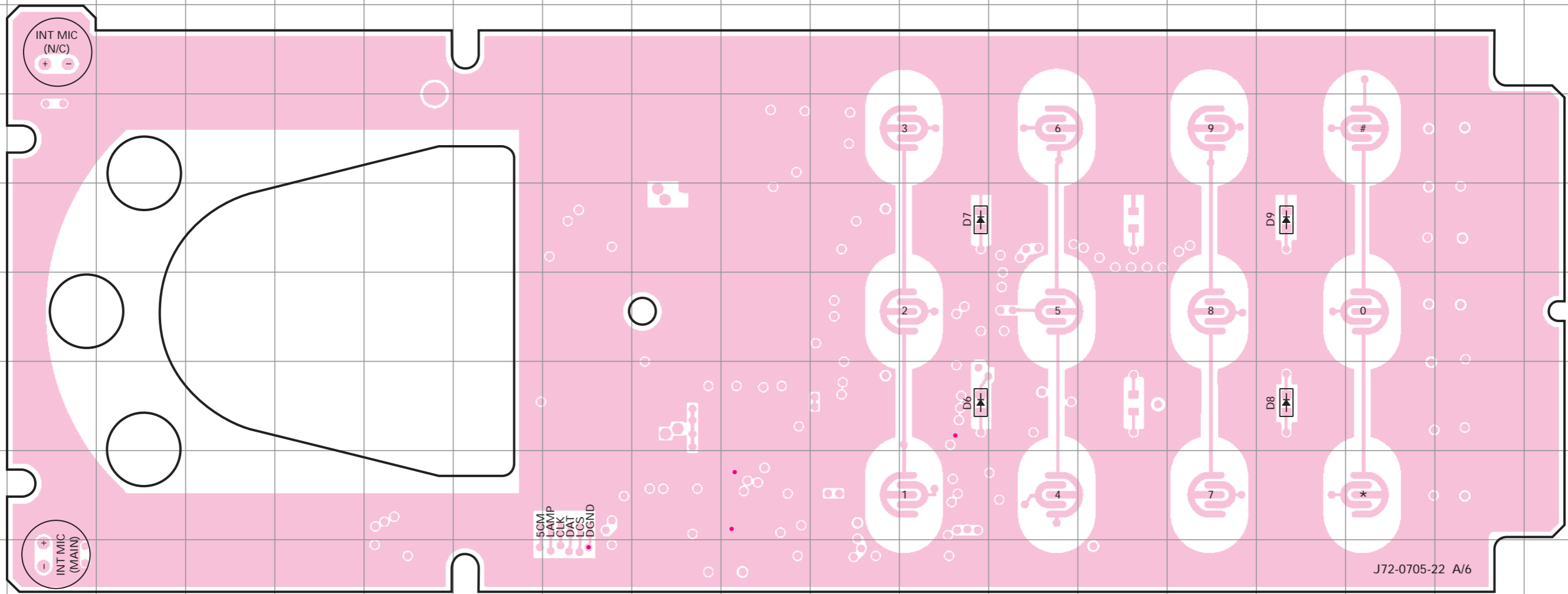

● Connect 1 and 4

TK-390 PC BOARD VIEW

TX-RX UNIT (X57-5400-XX) -10 : K,K4 -11 : K2 -12 : K3,K6 Component side view

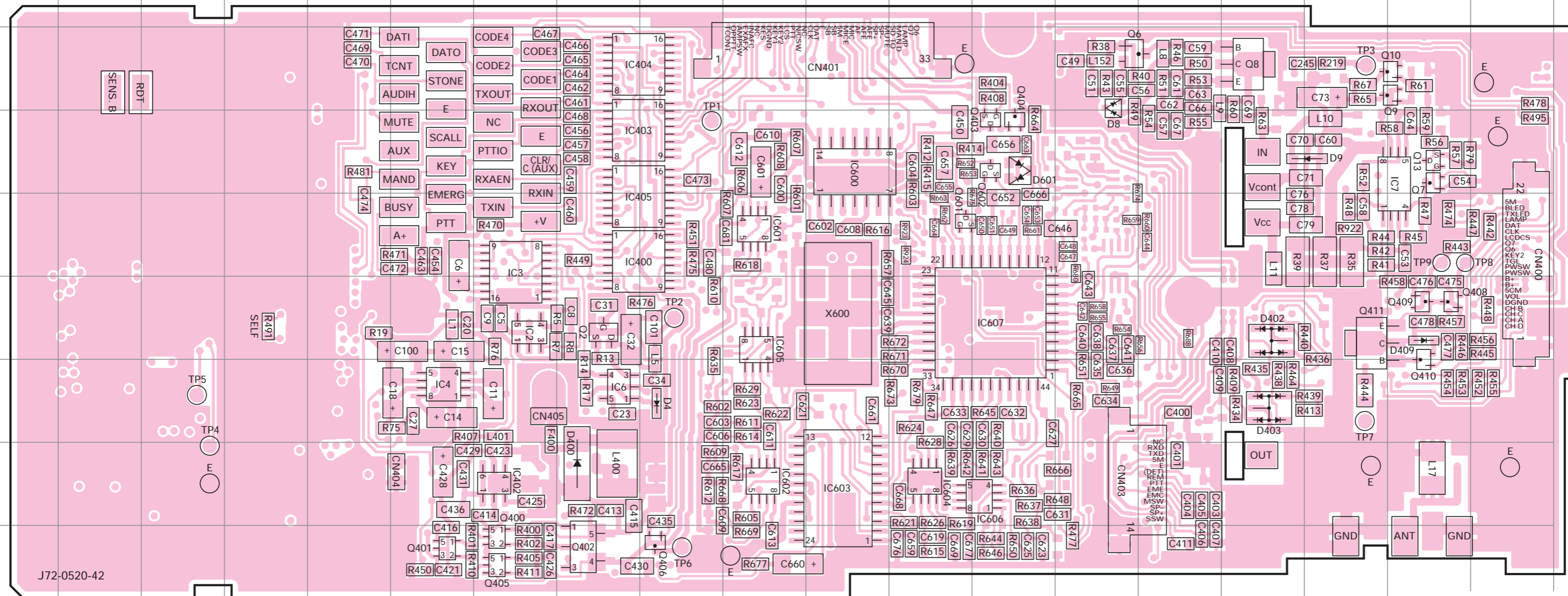

Ref No.	Address	Ref No.	Address	Ref No.	Address	Ref No.	Address
IC2	6G	IC602	8J	Q13	4R	Q601	5L
IC3	5G	IC603	8K	Q400	9G	Q602	4M
IC4	7F	IC604	8L	Q401	9F	D4	7I
IC6	7H	IC605	6J	Q402	9H	D8	3N
IC7	4R	IC606	8M	Q403	4M	D9	4Q
IC400	5H	IC607	6M	Q404	4M	D400	8H
IC402	8G	Q2	6H	Q405	9G	D402	6P
IC403	4H	Q6	3N	Q406	9I	D403	7P
IC404	3H	Q7	4R	Q408	6R	D409	6R
IC405	5H	Q8	3P	Q409	6R	D601	4M
IC600	4K	Q9	3R	Q410	7R		
IC601	5J	Q10	3R	Q411	6Q		

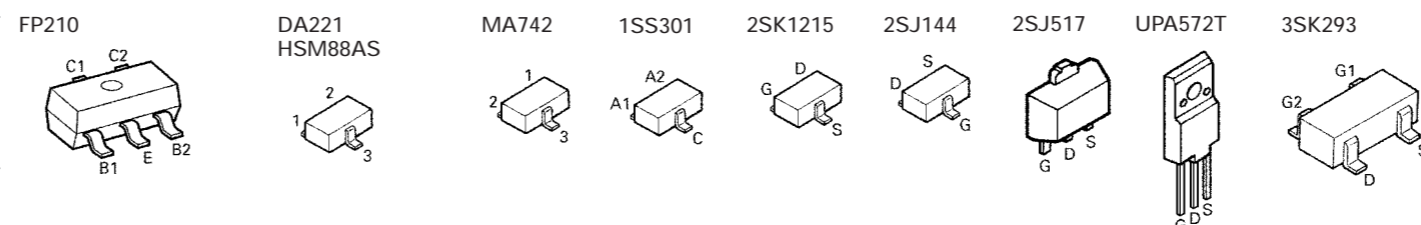
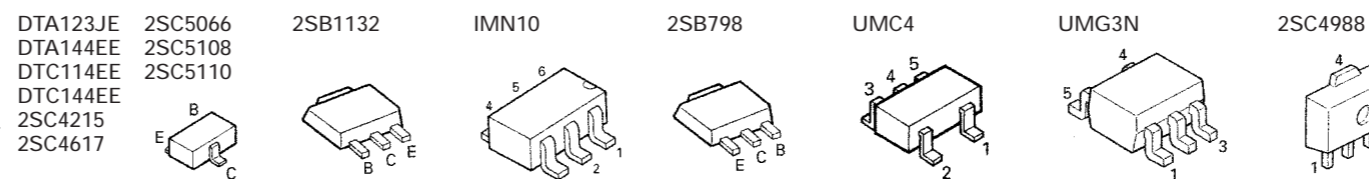

Component side

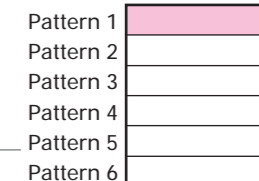

Foil side

TK-390 SCHEMATIC DIAGRAM

Note : Components marked with a dot (·) are parts of pattern 1.

- | | | |
|-------------------------------|---------------------|------------------------------|
| IC1 : TDA7053AT | Q5 : 2SC4617(S) | D2 : DTZ3.9(B) or UDZ3.9(B) |
| IC2 : BU4094BCFV | Q6 : 2SB798(DL.DK) | D12, 13, 15, 19, 20 : MAZ511 |
| IC3 : NJM2904V | Q7, 8, 15 : 2SK1824 | D16 : 1MN10 |
| X53-3930-XX(A/6) CONTROL UNIT | IC4-6 : TC7SH08FU | Q14 : UMC4 |
| | IC10 : TC7W04FU | |

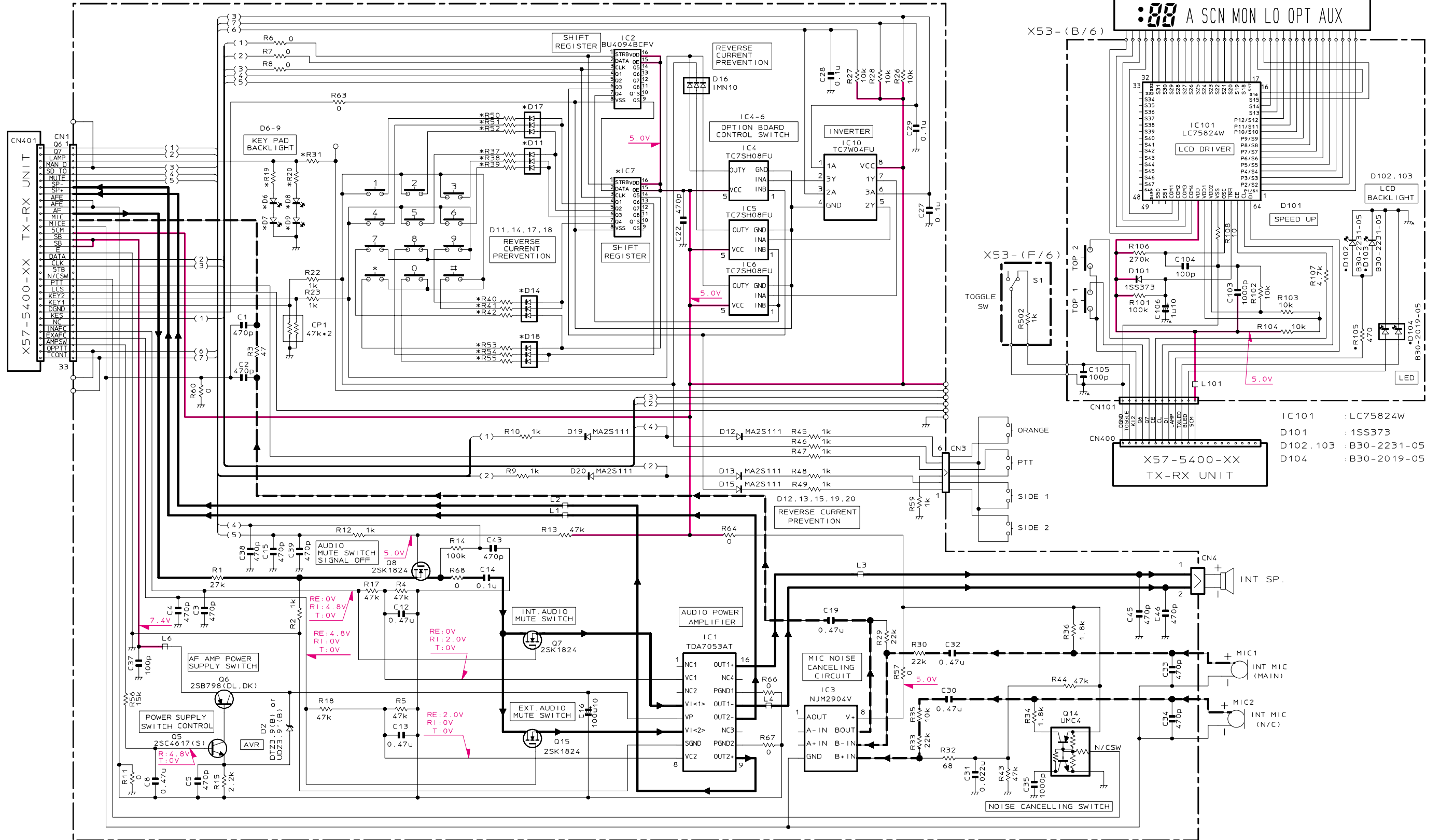

	D6	D7	D8	D9	D11	D14	D17	D18	R19	R20	R31	R37	R38	R39	R40	R41	R42	R50	R51	R52	R53	R54	R55	IC7	
-13	K, K2	NO	NO	NO	NO	NO	NO	NO	NO	NO	NO	NO	NO	NO	NO	NO	NO	NO	NO	NO	NO	NO	NO	NO	
-14	K4	B30-2171-05	B30-2171-05	B30-2171-05	B30-2171-05	1MN10	1MN10	1MN10	100	100	0	1k	1k	1k	1k	1k	1k	1k	1k	1k	1k	1k	1k	1k	BU4094BCFV
-15	K3	NO	NO	NO	NO	NO	NO	NO	NO	NO	NO	NO	NO	NO	NO	NO	NO	NO	NO	NO	NO	NO	NO	NO	NO
-16	K6	B30-2171-05	B30-2171-05	B30-2171-05	B30-2171-05	1MN10	1MN10	1MN10	100	100	0	1k	1k	1k	1k	1k	1k	1k	1k	1k	1k	1k	1k	1k	BU4094BCFV

TK-390 TK-390

BLOCK DIAGRAM

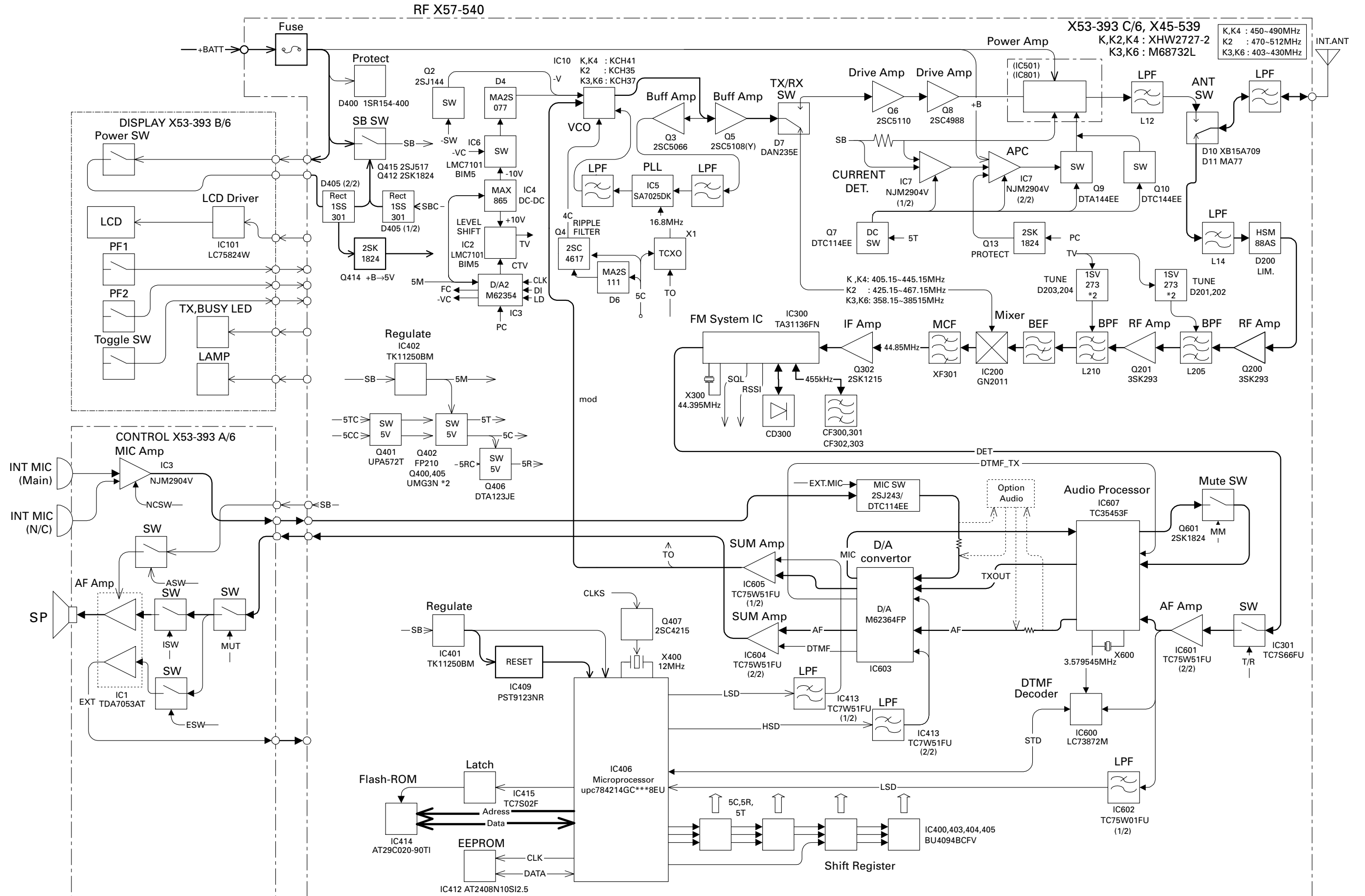

LEVEL DIAGRAM

Receiver Section

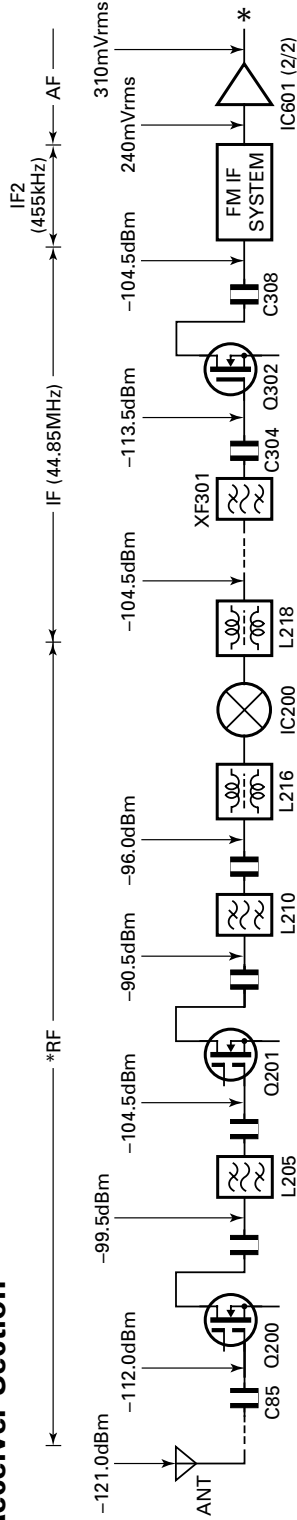

To make measurements in the AF section, connect the AC level meter. (ANT input : -47dBm, 1kHz FM, 3kHz DEV.)
In the RF section, use a 1000pF coupling capacitor. (The display shows the SSG input value required to obtain 12dB SINAD.)

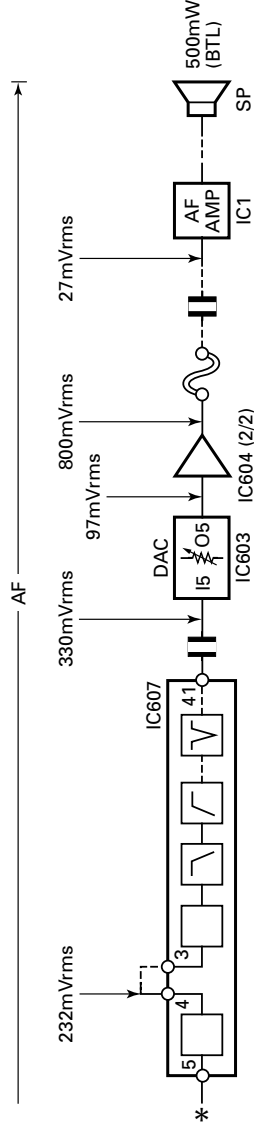

TERMINAL FUNCTION

CN No.	Pin No.	Name	I/O	Function
TX-RX UNIT (X57-5400-XX)				
CN400 for X53 (B/6)	1	CH D	I	CH switch data.
	2	CH A	I	CH switch data.
	3	CH C	I	CH switch data.
	4	CH B	I	CH switch data.
	5	E	-	GND.
	6	VOL	I	Voltage level input for audio control.
	7	5CM	-	5V.
	8	B+	-	Power input after passing through the fuse.
	9	B+	-	Power input after passing through the fuse.
	10	SB	-	Power output after power switch.
	11	SB	-	Power output after power switch.
	12	TOGGLE	I	Normally : 5V, switched toggle when connected GND.
	13	KEY2	I	Key input.
	14	Q6	O	Key scan IC Q6 signal output.
	15	Q7	O	Key scan IC Q7 signal output.
	16	LCDCS	O	Chip select output for LCD driver.
	17	CLK	O	Clock data output for LCD driver.
	18	DAT	O	Data output for LCD driver.
	19	LAMP	-	Backlight LED control. Normally : 0V, Lighting : 7.5V
	20	TXLED	-	TX LED control. Normally : 0V, Lighting : 7.5V
	21	BLED	-	Busy LED control. Normally : 0V, Lighting : 7.5V
	22	5M	-	5V.
CN401 for X53 (A/6)	1	TCONT	O	For optional board. (See page 22.)
	2	OPPTT	O	For optional board. (See page 22.)
	3	AMPSW	O	Audio AMP control switch output.
	4	EXAFC	O	External speaker switch control.
	5	INAFc	O	Internal speaker switch control.
	6	KRS	O	Key scan IC reset output.
	7	KCK	O	Key scan IC clock data output.
	8	SOD	-	Not use.
	9	KEY1	I	Key input.
	10	KEY2	I	Key input.
	11	LCS	-	Not use.
	12	PTT	I	PTT signal input.
	13	N/CSW	O	Noise canceler microphone switch output.
	14	NC	-	Not use.
	15	CLK	O	Clock data output.
	16	DAT	O	Data output.
	17	E	-	GND.
	18	SB	-	Power output after power switch.
	19	SB	-	Power output after power switch.
	20	5M	-	5V.
	21	MICE	-	MIC GND.
	22	MIC	I	MIC signal input.
	23	AF	O	Audio output.
	24	AFE	-	Audio GND.
	25	AFE	-	Audio GND.

CN No.	Pin No.	Name	I/O	Function
	26	SP+	I	BTL input + for external speaker.
	27	SP-	I	BTL input - for external speaker.
	28	MUTE	O	Audio mute signal output.
	29	SD TO	O	For optional board.
	30	MAN D	O	For optional board.
	31	LAMP	O	Backlight LED control. Normally : 0V, Lighting : 7.5V
	32	Q7	O	Key scan IC Q7 signal input.
33	Q6	O	Key scan IC Q6 signal input.	
CN402	1	AFE	-	Audio GND.
	2	AFE	-	AUdio GND.
CN403	1	SSW	I	EXT/INT speaker switch input.
	2	SP+	O	BTL output + for external speaker.
	3	SP-	O	BTL output - for external speaker.
	4	MSW	I	EXT/INT MIC switch input.
	5	EMC	I	External microphone input.
	6	ME	-	External microphone GND.
	7	PTT	I	External PTT input.
	8	PF	I	Programmable function key input.
	9	NC	-	Not use.
	10	E	-	GND
	11	5M	-	5V.
	12	TXD	O	Serial data output.
	13	RXD	I	Serial data input.
	14	NC	-	Not use.
CONTROL UNIT (X53-3930-XX) (A/6)				
CN1 for X57	1	Q6	O	Key scan IC Q6 output.
	2	Q7	O	Key scan IC Q7 output.
	3	LAMP	I	Backlight LED control. Normally : 0V, Lighting : 7.5V
	4	MAN D	I	For optional board. (See page 22.)
	5	SD TO	I	For optional board. (See page 22.)
	6	MUTE	I	Audio mute signal input.
	7	SP-	O	BTL output - for external speaker.
	8	SP+	O	BTL output + for external speaker.
	9	AFE	-	Audio GND.
	10	AFE	-	Audio GND.
	11	AF	I	Audio output.
	12	MIC	O	MIC signal input.
	13	MICE	-	MIC GND.
	14	5M	-	5V.
	15	SB	-	Power output after power switch.
	16	SB	-	Power output after power switch.
	17	E	-	GND.
	18	DATA	I	Data input.
	19	CLK	I	Clock data input.
	20	NC	-	Not use.
	21	N/CSW	I	Noise canceler microphone switch input.
	22	PTT	O	PTT signal output.
	23	LCS	-	Not use.
	24	KEY2	O	Key output.
	25	KEY1	O	Key output.

TERMINAL FUNCTION / KNB-17A (Ni-Cd BATTERY)

CN No.	Pin No.	Name	I/O	Function
	26	NC	-	Not use.
	27	KCK	I	Key scan IC clock data input.
	28	KRS	I	Key scan IC reset input.
	29	INAFc	I	Internal speaker switch input.
	30	EXAFc	I	External speaker switch input.
	31	AMPSW	I	Audio AMP control switch input.
	32	OPPTT	I	For optional board. (See page 22.)
	33	TCONT	I	For optional board. (See page 22.)
CN2 for X57	1	AFE	-	Audio GND.
	2	AFE	-	Audio GND.
CN3	1	Q8	O	Key scan IC Q8 signal output.
	2	Q7	O	Key scan IC Q7 signal output.
	3	PTTE	-	PTT GND.
	4	PTT	I	Normally : 5V, transmit when connected GND.
	5	KI1	I	Key input.
	6	Q6	O	Key scan IC Q6 signal output.
CN4	1	+	-	BTL + output for internal speaker.
	2	-	-	BTL - output for internal speaker.
CONTROL UNIT (X53-3930-XX) (B/6)				
CN101 for X57	1	E	-	GND.
	2	TOGGLE	O	Normally : 5V, switched toggle when connected GND.
	3	KI2	O	Key output.
	4	Q6	I	Key scan IC Q6 signal input.
	5	Q7	I	Key scan IC Q7 signal input.
	6	CE	I	Chip select input for LCD driver.
	7	CL	I	Clock data input for LCD driver.
	8	DI	I	Data input for LCD driver.
	9	LAMP	-	Backlight LED control. Normally : 0V, Lighting : 7.5V
	10	TX LED	-	TX LED control. Normally : 0V, Lighting : 7.5V
	11	BLED	-	Busy LED control. Normally : 0V, Lighting : 7.5V
	12	5M	-	5V.

KNB-17A External View



KNB-17A Circuit Diagram

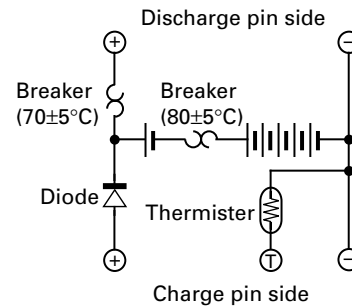

KNB-17A Specifications

Voltage	7.2V (1.2V x 6)
Charging current	1500mAh
Dimensions (mm)	58.0 W x 110.8 H x 20.0 D (Projections included)
Charger and charging time	
KSC-19 (Normal Charger)	Approx. 8 hours
KSC-20 (Rapid charger)	Approx. 1.3 hour
Weight	220g

KSC-19 (CHARGER) / KSC-20 (RAPID CHARGER) / KPG-36 (PROGRAMMING INTERFACE CABLE) / KRA-15 (WHIP ANTENNA)

KSC-19 External View



KPG-36 External View



KSC-19 Charging

KNB-17A	
Voltage	7.2V
Battery capacity	1500mAh
Charging time	Approx. 8 hours

KSC-20 External View



KRA-15 External View

M	: 450~490MHz
M2	: 470~512MHz
M3	: 403~430MHz



KSC-20 Specifications

Charging current	1100mA±150mA
Charging time	KNB-17A : 80 min.±24%
Source voltage	Approx 15V
Ambient temperature	0°C~40°C
Dimensions	105 W x 135 D x 52 H (mm)
Weight	0.18kg

SPECIFICATIONS

GENERAL

Frequency Range	450 to 490MHz : K,K4	470~512MHz : K2	403~430MHz : K3,K6
Number of Channels	160 channels		
Channel Spacing	Wide : 25kHz, Narrow : 12.5kHz (PLL channel step 5kHz, 6.25kHz)		
Battery Voltage	7.5V DC \pm 20%		
Battery Life	10 hours at 4W (5-5-90 duty cycle)		
Temperature Range	-30°C to +60°C (-22°F to +140°F)		
Dimensions and Weight	6-3/32" (155mm) H x 2-5/16" (58mm) W x 1-1/2" (38mm) D, 1.25 lbs (565g)		
With Keypad Model	6-3/32" (155mm) H x 2-5/16" (58mm) W x 1-9/16" (39.5mm) D		

RECEIVER (Measurements made per EIA standard EIA-603)

Sensitivity	
EIA 12dB SINAD	0.25 μ V
20dB Quieting	0.35 μ V
Selectivity	Wide : -73dB, Narrow : -68dB
Intermodulation	Wide : -73dB, Narrow : -65dB
Spurious and Image Rejection	-73dB
Audio Power Output	500mW at less than 3% distortion
Frequency Stability	\pm 0.0002% from -30°C to +60°C
Channel Frequency Spread	40MHz : K,K4 42MHz : K2 27MHz : K3,K6

TRANSMITTER (Measurements made per EIA standard EIA-603)

RF Power Output	Hi : 4W, Low : 1W
Spurious and Harmonics	-70dB
Type of Emission	Wide : 16K0F3E, Narrow : 11K0F3E
FM Noise	Wide : -45dB, Narrow : -40dB
Audio Distortion	Less than 3.0% at 1000Hz
Frequency Stability	\pm 0.0002% from -30°C to +60°C
Channel Frequency Spread	40MHz : K,K4 42MHz : K2 27MHz : K3,K6

KENWOOD CORPORATION

14-6, Dogenzaka 1-chome, Shibuya-ku, Tokyo 150-8501, Japan

KENWOOD SERVICE CORPORATION

P.O. BOX 22745, 2201 East Dominguez Street, Long Beach, CA 90801-5745, U.S.A.

KENWOOD ELECTRONICS CANADA INC.

6070 Kestrel Road, Mississauga, Ontario, Canada L5T 1S8

KENWOOD ELECTRONICS DEUTSCHLAND GMBH

Rembrücker Str. 15, 63150 Heusenstamm, Germany

KENWOOD ELECTRONICS BELGIUM N.V.

Mechelsesteenweg 418 B-1930 Zaventem, Belgium

KENWOOD ELECTRONICS FRANCE S.A.

13, Boulevard Ney, 75018 Paris, France

KENWOOD ELECTRONICS U.K. LIMITED

KENWOOD House, Dwight Road, Watford, Herts., WD1 8EB United Kingdom

KENWOOD ELECTRONICS EUROPE B.V.

Amsterdamseweg 37, 1422 AC Uithoorn, The Netherlands

KENWOOD ELECTRONICS ITALIA S.p.A.

Via G. Sirtori, 7/9 20129 Milano, Italy

KENWOOD IBERICA S.A.

Bolivia, 239-08020 Barcelona, Spain

KENWOOD ELECTRONICS AUSTRALIA PTY. LTD.

(A.C.N. 001 499 074)

16 Giffnock Avenue, Centrecourt Estate, North Ryde, N.S.W. 2113 Australia

KENWOOD ELECTRONICS (HONG KONG) LTD.

Unit 3712-3724, Level 37, Tower one Metroplaza, 223 Hing Fong Road, Kwai Fong, N.T., Hong Kong

KENWOOD ELECTRONICS TECHNOLOGIES(S) PTE LTD.

Sales Marketing Division

1 Ang Mo Kio Street 63, Singapore 569110